

**TAMPA-HILLSBOROUGH COUNTY  
EXPRESSWAY AUTHORITY**

**ADDENDUM NO. 1**

**FOR**

**REQUEST FOR QUALIFICATIONS**

**ITS NETWORK SUPPORT SERVICES**

**RFQ No. O-01218**

## **ADDENDUM NO. 1**

PROJECT NAME: **ITS Network Support Services** ~ DATE OF ADDENDUM: **12/14/18**

**TO ALL PROSPECTIVE BIDDERS:**

**PLEASE NOTE THE FOLLOWING ADDENDUM TO THE RFQ:**

The following are documents are added to the subject project:

1. Cohu Camera Documents
2. DMS Model & Description
3. DMS Specification Documents
4. Rugged Switch Specifications
5. Video Wall Specifications

**Bidders MUST** acknowledge receipt of this Addendum by signing, dating and returning the completed Acknowledgement of Receipt of Addendum form **with Bidder's proposal**.

All other items, conditions, and specifications in the ITB document not specifically changed by the Addendum remain unchanged.

Bidders failing to acknowledge the addendum issued may be deemed non-responsive to the LOI. Please send all questions to THEA's Procurement Manager, Man Le, via email at [Man.Le@tampa-xway.com](mailto:Man.Le@tampa-xway.com).

**ACKNOWLEDGEMENT OF RECEIPT OF ADDENDUM and/or LETTER OF CLARIFICATION**

Were Addenda issued on this Solicitation?

Yes

No

Were Letter of Clarification issued on this Solicitation?

Yes

No

I (We) hereby acknowledge receipt of the following Addendum/Addenda issued in reference to this solicitation by listing the Addenda by number, date and signing the form:

Addendum \_\_\_\_\_ Date: \_\_\_\_\_

Addendum \_\_\_\_\_ Date: \_\_\_\_\_

Addendum \_\_\_\_\_ Date: \_\_\_\_\_

Letter of Clarification \_\_\_\_\_ Date: \_\_\_\_\_

Letter of Clarification \_\_\_\_\_ Date: \_\_\_\_\_

Letter of Clarification \_\_\_\_\_ Date: \_\_\_\_\_

**BIDDER:**

By: \_\_\_\_\_

Authorized Signature

\_\_\_\_\_  
Printed Name of Signer

\_\_\_\_\_  
Title of Signer

\_\_\_\_\_  
Date Signed

**[END OF ACKNOWLEDGMENT OF RECEIPT FORM]**



## Series 4220HD

H.264 High-Definition, IP67 Dome Positioning System

Available Q1 2016



### Advanced Optics

- Superior 1080p image quality
- Powerful 30x optical zoom with 12x digital zoom (360x total)
- Image defog/dehaze analytics
- Electronic image stabilization (EIS)
- Dark scene enhanced intensity
- Bright source whiteout reduction

### Rugged Construction

- Operates in hurricane force winds
- Built-in electrical transient/surge protection to CISPR 24 levels
- Purged and pressurized IP67 ingress protection
- NEMA TS2 temperature range, -40°C to 75°C

### Flexible Installation and Seamless Interoperability

- ONVIF Profile S compliant
- NTCIP 1205 camera control compliant
- User defined video stream profiles
- Presets, tours, sectors and privacy zones
- H.264 Base/Main/High profiles and MJPEG encoding
- Web server configuration, operation and viewing
- Single Cat5e cable with PoE++
- Pendant, wall, pole and corner mounting bracket options

CohuHD Costar's 4220HD dome positioning system combines crystal clear HD image quality, bandwidth efficient H.264 compression, smooth variable speed positioning and IP67 protection delivering the CohuHD quality and performance you expect!

The 4220HD provides full 1080p imaging with 30x optical zoom, delivering full frame rate HD images over the entire zoom range for very cost effective long-range surveillance applications.

True day/night technology using a removable IR cut filter produces exceptional low light sensitivity down to 0.00025 fc.

For installations subject to wind or vibration, electronic image stabilization assures steady, clear images and enables the system designer to utilize existing bridge sign and traffic light poles for camera mounting.

The 4220HD includes defog/dehaze image processing, enhancing video performance in foggy and hazy conditions encountered in surveillance and traffic monitoring applications.

The 4220HD includes variable hi-speed pan and tilt drive, with 360° continuous pan and +5° to -90° tilt. Fast positioning speeds result in 180° movements in less than 1.5 seconds. The high-torque motor and gearing design, insures the positioner maintains position in high shock, vibration and hurricane force winds.

Providing multiple video stream profiles, the 4220HD delivers up to 5 or more independently configured H.264/MJPEG streams as well as analog video output with serial RS422 camera PTZ control.

Use of the IP and analog output allows integrating with analog systems today while providing a smooth transition to HD Video over IP tomorrow.

The 4220HD provides a full function web server, allowing complete administrative and operator control capabilities.

Administrative features include configuring network settings, user password assignments, setting video streaming properties, configuring camera imaging properties, defining presets and tours, and assigning camera ID labels.

The 4220HD is designed to operate in harsh weather with its IP67 enclosure protection. This eliminates the effects of water intrusion, pollutants and corrosives.

**CohuHD delivers years of clean, reliable images and backs it with a world class three year warranty.**



youtube.com/CohuHD  
linkedin.com/company/CohuHD  
twitter.com/CohuHD  
facebook.com/CohuHD  
CohuHD.com

©CohuHD Costar™, LLC reserves the right to change specifications without notice

(858) 391-1800



# Series 4220HD

H.264 High-Definition, IP67 Dome Positioning System



## DIMENSION INCHES (MM)

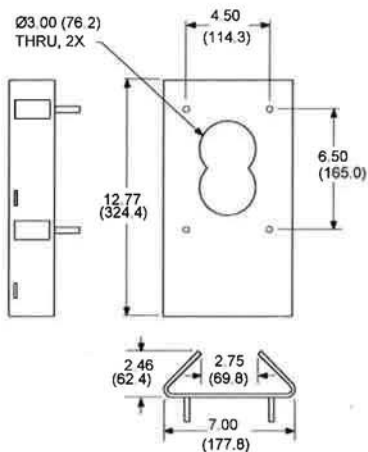
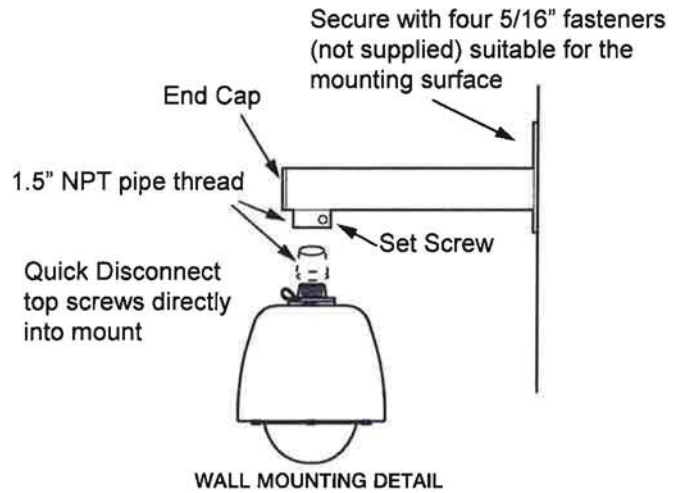
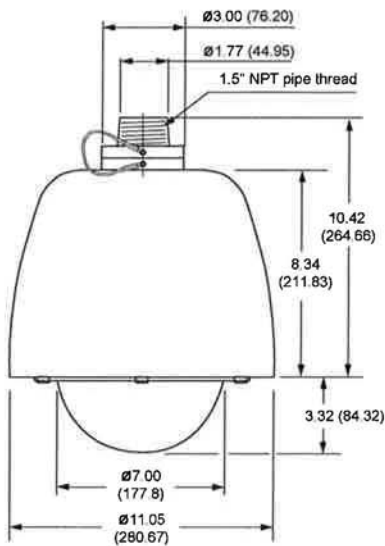

**Pole Mount 8518-2**  
(Also Includes 7411420-001 Wall Mount)

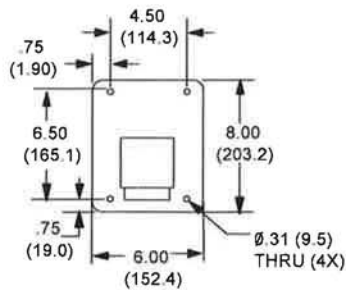
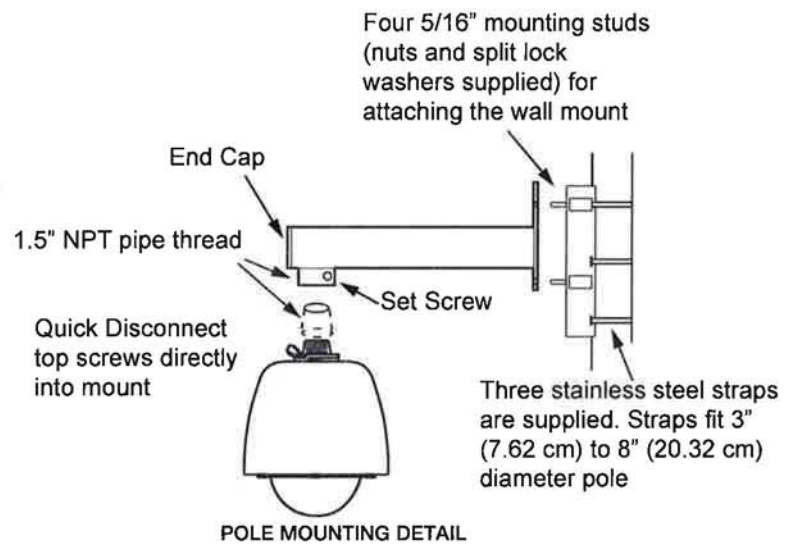

**Wall Mount 7411420-001**

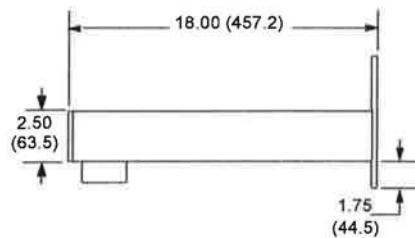

## 2. DMS Model & Description

### Tampa Hillsborough Expressway Authority Systemwide Full Color OMS

Item No.	Model	Description	Qty
	VF-2420-80x224-20- RGB	618-DE04, 618-DW05, 618-DE06, 618-DW07, DT-C01, and MER-VS01 and MER-VS02 - Front Access OMS, Full Color, 20mm Pixel Pitch, 2 Lines using 18" Characters; 3 Lines using 12" Characters	7
2	VF-2420-64x320-20- RGB	618-VW03 Front Access OMS, Full Color, 20mm Pixel Pitch, 2 Lines using 18" Characters; 3 Lines using 12" Characters	1
3	UPS System	UPS (1 Hour Back-up) for 2/3 Line Front Access OMS. UPS Includes 1 Head Unit and 4 Batteries. To Be Mounted in Control Equipment Cabinet	8
4	VF-2420-48x128-20- RGB	618-VE04 & Portable Replacement - Front Access OMS, Full Color, 20mm Pixel Pitch	2
5	UPS System	UPS (1 Hour Back-up) for 618-VE04 Front Access OMS. UPS Includes 1 Head Unit and 4 Batteries. To Be Mounted in Control Equipment Cabinet	2
6	VM-1020-32x160-20- RGB	BRN-N10 - Front Access OMS, Full Color, 20mm Pixel Pitch	1
7	UPS System	UPS (1 Hour Back-up) for BRN-N10 Front Access OMS. UPS Includes 1 Head Unit and 4 Batteries. To Be Mounted in Control Equipment Cabinet	1
8	VM-1020-24x288-20- RGB	34-C01, 301-C01, 78-C01, DT-C02, DT-C04, OT-COS, DT-N06 - Front Access OMS, Full Color, 20mm Pixel Pitch. Includes OMS Power and Control Equipment To Be Mounted in Control Equipment	4
9	UPS System	UPS (1 Hour Back-up) for DT-C02, DT-C04, OT-COS, DT-N06 Front Access OMS. UPS Includes 1 Head Unit and 2 Batteries. To Be Mounted in Control Equipment Cabinet.	4
10	VM-1020-24x272-20- RGB	34-C01, 301-C01, 78-C01 Front Access OMS - Full Color, 20mm Pixel Pitch. Includes OMS Power and Control Equipment To Be Mounted in Control Equipment Cabinet.	3

## D

11	UPS System	UPS (1 Hour Back-up) for 34-C01, 301-C01, 78-C01 Front Access OMS. UPS Includes 1 Head Unit and 2 Batteries. To Be Mounted in Control Equipment Cabinet	3
12	VM-1020-24x224-20- RGB	BRN-C04, BRN-C05, BRN-C06, BRN-C07 Front Access OMS - Full Color, 20mm Pixel Pitch. Includes OMS Power and Control Equipment To Be Mounted in Control Equipment Cabinet.	4
13	VX-2428-32x48-20- RGB	BRN-C06, BRN-C07 Front Access OMS - Full Color, 20mm Pixel Pitch. Includes OMS Power and Control Equipment To Be Mounted in Control Equipment Cabinet. 2 Locations of 2 Panels per Site.	4
14	UPS System	UPS (1 Hour Back-up) for BRN-C04, BRN-COS, BRN-C06, BRN-C07 Front Access OMS. UPS Includes 1 Head Unit and 4 Batteries. To Be Mounted in Control Equipment Cabinet.	4
15	VX-2428-32x48-20- RGB	OT-C03 Front Access OMS - Full Color, 20mm Pixel Pitch. Includes OMS Power and Control Equipment To Be Mounted in Control Equipment Cabinet. 1 Location of 3 Panels per Site.	3
16	UPS System	UPS (1 Hour Back-up) for OT-C03 Front Access OMS. UPS Includes 1 Head Unit and 4 Batteries. To Be Mounted in Control Equipment Cabinet.	1
17	VM-1020-24x192-20- RGB	34-C02, 301-C03, 78-C02 Front Access OMS - Full Color, 20mm Pixel Pitch. Includes OMS Power and Control Equipment To Be Mounted in Control Equipment Cabinet.	3
18	UPS System	UPS (1 Hour Back-up) for 34-C02, 301-C03, 78-C02 Front Access OMS. UPS Includes 1 Head Unit and 2 Batteries. To Be Mounted in Control Equipment Cabinet.	3
19	VM-1020-16x192-20- RGB	BRN-N15 Front Access OMS - Full Color, 20mm Pixel Pitch. Includes OMS Power and Control Equipment To Be Mounted in Control Equipment Cabinet.	1
20	UPS System	UPS (1 Hour Back-up) for BRN-N15 Front Access OMS. UPS Includes 1 Head Unit and 2 Batteries. To Be Mounted in Control Equipment Cabinet	1
21	VM-1020-24x48-20- RGB	BRN-N13 & BRN-N16 Front Access OMS - Full Color, 20mm Pixel Pitch. Includes OMS Power and Control Equipment To Be Mounted in Control Equipment Cabinet.	2

---

## D

22	UPS System	UPS (1 Hour Back-up) for BRN-N13 & BRN-N16 Front Access OMS. UPS Includes 1 Head Unit and 2 Batteries. To Be Mounted in Control Equipment Cabinet.	2
23	VM-1020-24x32-20- RGB	BRN-COB & BRN-N09 Front Access OMS - Full Color, 20mm Pixel Pitch. Includes OMS Power and Control Equipment To Be Mounted in Control Equipment Cabinet. 2 Locations of 1 Panel per Site.	2
24	VM-1020-24x32-20- RGB	BRN-NC11 & BRN-N14 Front Access OMS - Full Color, 20mm Pixel Pitch. Includes OMS Power and Control Equipment To Be Mounted in Control Equipment Cabinet. 2 Location of 2 Panel per Site.	4
25	UPS System	UPS (1 Hour Back-up) for BRN-COB, BRN-N09, BRN-NC11, & BRN-N14 Front Access OMS. UPS Includes 1 Head Unit and 2 Batteries. To Be Mounted in Control Equipment Cabinet.	4

---

# VANGUARD® VF-2420-64x224-20-RGB

Full-Color (RGB)

## Power Specifications

Model	Viewing Angle (HxV)	Amps Per Leg <sup>3</sup>	Typical Power <sup>4</sup>
VF-2420-64x224-20-RGB	30° x 30°	20	1486 W

## Sample Character Capacity<sup>2</sup>

Character Height	Lines/ Characters	Example Font Size	Interline Spacing	Character Spacing
18"	2/12	23x15_3	12	4
12"	3/17	15x10_2	8	3
9"	3/22	12x8_2	6	2
6"	6/37	7x5_1	4	1

Display Technology	High-intensity LED
Cabinet Access	Front access
Cabinet Enclosure	NEMA 3R
Face Panel	Aluminum mask over polycarbonate face panel
Weight	1030 lbs. (468 kg)
Dimensions <sup>1</sup>	5'8" x 16'6" x 1'4" (1.73 m x 5.03 m x .38 m)
Operating Temp. Range	-30° F to +165° F (-34° C to +74° C)
Humidity Range	0 to 99%, non-condensing
Ventilation	Pressurized, forced-air ventilation system
Controller Location	Sign cabinet or equipment cabinet
Display Type	Full-matrix (variable text and graphics)
Active Area	4'3" x 15'2" (1.32 m x 4.62 m)
Top/Bottom Border Width	8" (203 mm)
Left/Right Border Width	8" (203 mm)
Pixel Matrix	64 rows x 224 columns
Pixel Pitch	20mm (.81")
Viewing Distance	300' (91 m) using 6" characters
Sign Intensity	12,400 candelas/m <sup>2</sup> minimum (white)
LED Color	Full color (32,000 distinct colors using red, green and blue LEDs)
Power Requirements	120/240 VAC, single-phase power (3-wires plus ground)
Communications Protocol	NTCIP 1203 v02
Communications Options	Cellular, fiber optic, direct Ethernet and radio Ethernet
Structural Design Standard	AASHTO
NEMA Standards	NEMA TS 4 Section 2 Environmental Requirements

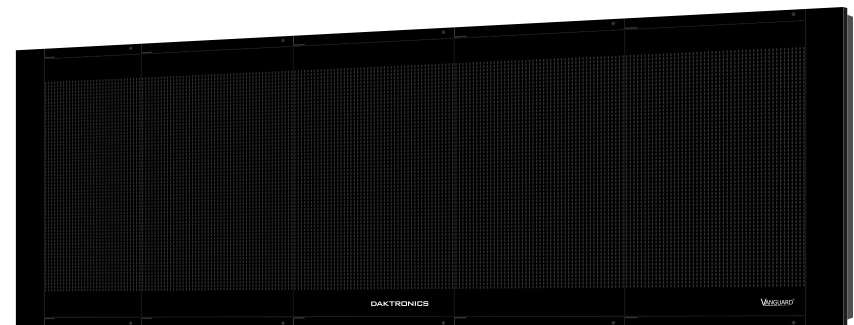

## NOTES

1. Display cabinet depth measurement includes "Z" mounting brackets on the rear of the cabinet.
2. Many other font sizes are available.
3. Amps per leg calculation is based on the maximum load of a typical DMS, including a fully-loaded 15A convenience outlet. This value is measured for a 120/240 3W+G system and will vary with auxiliary options installed in the DMS.
4. Typical power includes a partially-illuminated LED sign (38% of the pixels at full intensity), the sign controller and ventilation system.
5. Sign front face paint color is semi-gloss black. Other sides are mill finish aluminum.
6. With the continuous improvement of all Daktronics products, the features and measurements on this page are subject to change without notice.
7. The product illustration on this page is for conceptual purposes only and may not represent the actual dimensions of the specified display.

# VANGUARD® VF-2420-64x320-20-RGB

Full-Color (RGB)

Display Technology	High-intensity LED
Cabinet Access	Front access
Cabinet Enclosure	NEMA 3R
Face Panel	Aluminum mask over polycarbonate face panel
Weight	1440 lbs. (654 kg)
Dimensions <sup>1</sup>	5'8" x 23'0" x 1'4" (1.73 m x 7.01 m x .38 m)
Operating Temp. Range	-30° F to +165° F (-34° C to +74° C)
Humidity Range	0 to 99%, non-condensing
Ventilation	Pressurized, forced-air ventilation system
Controller Location	Sign cabinet or equipment cabinet
Display Type	Full-matrix (variable text and graphics)
Active Area	4'3" x 21'8" (1.32 m x 6.60 m)
Top/Bottom Border Width	8" (203 mm)
Left/Right Border Width	8" (203 mm)
Pixel Matrix	64 rows x 320 columns
Pixel Pitch	20mm (.81")
Viewing Distance	300' (91 m) using 6" characters
Sign Intensity	12,400 candelas/m <sup>2</sup> minimum (white)
LED Color	Full color (32,000 distinct colors using red, green and blue LEDs)
Power Requirements	120/240 VAC, single-phase power (3-wires plus ground)
Communications Protocol	NTCIP 1203 v02
Communications Options	Cellular, fiber optic, direct Ethernet and radio Ethernet
Structural Design Standard	AASHTO
NEMA Standards	NEMA TS 4 Section 2 Environmental Requirements

## Power Specifications

Model	Viewing Angle (HxV)	Amps Per Leg <sup>3</sup>	Typical Power <sup>4</sup>
VF-2420-64x320-20-RGB	30° x 30°	28	2081 W

## Sample Character Capacity<sup>2</sup>

Character Height	Lines/ Characters	Example Font Size	Interline Spacing	Character Spacing
18"	2/17	23x15_3	12	4
12"	3/24	15x10_2	8	3
9"	3/32	12x8_2	6	2
6"	6/53	7x5_1	4	1

## NOTES

1. Display cabinet depth measurement includes "Z" mounting brackets on the rear of the cabinet.
2. Many other font sizes are available.
3. Amps per leg calculation is based on the maximum load of a typical DMS, including a fully-loaded 15A convenience outlet. This value is measured for a 120/240 3W+G system and will vary with auxiliary options installed in the DMS.
4. Typical power includes a partially-illuminated LED sign (38% of the pixels at full intensity), the sign controller and ventilation system.
5. Sign front face paint color is semi-gloss black. Other sides are mill finish aluminum.
6. With the continuous improvement of all Daktronics products, the features and measurements on this page are subject to change without notice.
7. The product illustration on this page is for conceptual purposes only and may not represent the actual dimensions of the specified display.

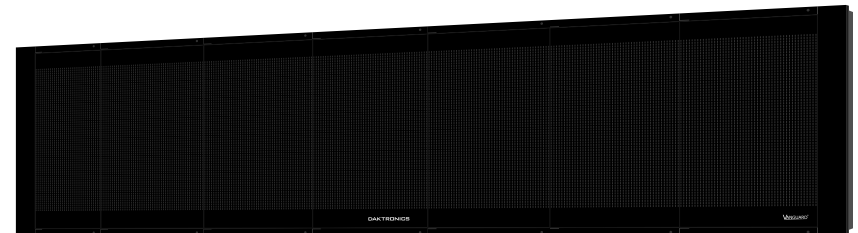

# VANGUARD® VM-1020-16x192-20-RGB

Full-Color (RGB)

## Power Specifications

Model	# of LED panels	Viewing Angle (HxV)	Amps Per Leg	Typical Power <sup>1</sup>
VM-1020-16x192-20-RGB	1	30° x 30°	16	322 W

## Sample Character Capacity

Character Height	Characters	Character Spacing	Example Font Size
9"	1/19	2	12x8_2
12	1/14	3	15x10_2

Display Technology	High-intensity LED
Cabinet Access	Front access
Cabinet Enclosure	NEMA 3R
Face Panel	Aluminum mask over polycarbonate face panel
Weight	166 lbs.
Dimensions	1'4" x 13'4" x 5"
Operating Temp. Range	-30° F to +165° F (-34° C to +74° C)
Humidity Range	0 to 99%, non-condensing
Controller Location	Equipment cabinet
Display Type	Full-matrix (variable text and graphics)
Active Area	1'1" x 13'1"
Top/Sides Border Width	1.625" (41 mm)
Bottom Border Width	1" (26 mm)
Pixel Matrix	16 rows x 192 columns
Pixel Pitch	20mm (.81")
Viewing Distance	600' using 12" characters
Sign Intensity	12,400 candelas/m <sup>2</sup> minimum (white)
LED Color	Full color (32,000 distinct colors using red, green and blue LEDs)
Site Power Requirements <sup>2</sup>	120/240 VAC, single-phase power (3-wires plus ground)
Sign Power Requirements <sup>6</sup>	24 VDC
Communications Protocol	NTCIP 1203 v02
Communications Options	Cellular, fiber optic, direct Ethernet and radio Ethernet
Structural Design Standard	AASHTO
NEMA Standards	NEMA TS 4 Section 2 Environmental Requirements
Critical Components	Located in equipment cabinet

## NOTES

1. Typical power includes a partially-illuminated LED sign (38% of the pixels at full intensity) and the sign controller. For any other site configuration contact Daktronics.
2. VM-1020 Site Power Requirements include required 120/240 VAC 3-wires plus ground to equipment cabinet.
3. Sign front face paint color is semi-gloss black. Other sides are mill finish aluminum.
4. With the continuous improvement of all Daktronics products, the features and measurements on this page are subject to change without notice.
5. The product illustration on this page is for conceptual purposes only and may not represent the actual dimensions of the specified display.
6. 24VDC from equipment cabinet to sign required - see Daktronics riser diagram.

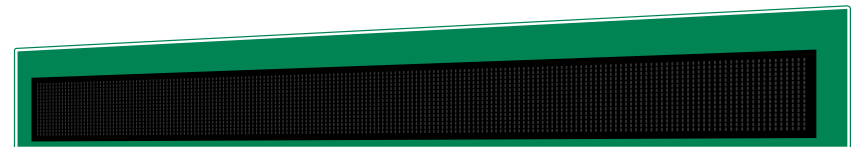

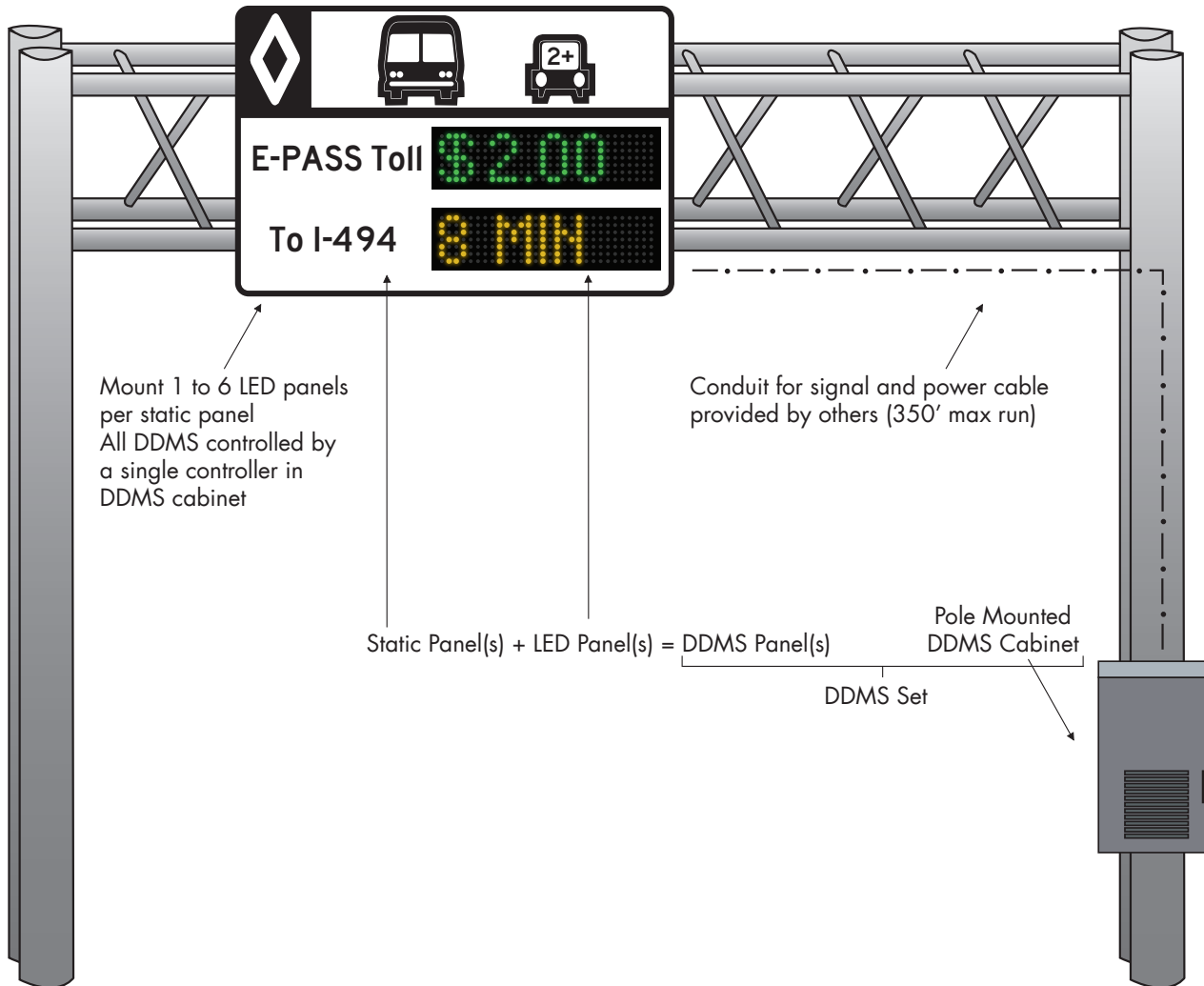

## VM-1020 DDMS Parameters

- › A DDMS set includes: 1 - 6 LED panel(s) and a DDMS cabinet
- › Multiple LED panels can be mounted to a single or multiple static panels
- › Multiple lines require multiple LED panels
- › LED panels are flexible in their ability to be aligned and oriented to static text on the static panel
- › Each LED panel employs a single line matrix
- › Max power cable run is 350' from farthest LED panel to DDMS cabinet
- › All LED panels must be the same matrix width
- › Toll, travel time and status information can be intermixed and displayed on multiple LED panels within a set

## Optional Equipment

Mounting Kit

For additional configuration options, contact Daktronics.

# VANGUARD® VM-1020-24x48-20-RGB

Full-Color (RGB)

Display Technology	High-intensity LED
Cabinet Access	Front access
Cabinet Enclosure	NEMA 3R
Face Panel	Aluminum mask over polycarbonate face panel
Weight	84 lbs.
Dimensions	1'11" x 3'7" x 5"
Operating Temp. Range	-30° F to +165° F (-34° C to +74° C)
Humidity Range	0 to 99%, non-condensing
Controller Location	Equipment cabinet
Display Type	Full-matrix (variable text and graphics)
Active Area	1'8" x 3'4"
Top/Sides Border Width	1.625" (41 mm)
Bottom Border Width	1" (26 mm)
Pixel Matrix	24 rows x 48 columns
Pixel Pitch	20mm (.81")
Viewing Distance	1100' using 18" characters
Sign Intensity	12,400 candelas/m <sup>2</sup> minimum (white)
LED Color	Full color (32,000 distinct colors using red, green and blue LEDs)
Site Power Requirements <sup>2</sup>	120/240 VAC, single-phase power (3-wires plus ground)
Sign Power Requirements <sup>6</sup>	24 VDC
Communications Protocol	NTCIP 1203 v02
Communications Options	Cellular, fiber optic, direct Ethernet and radio Ethernet
Structural Design Standard	AASHTO
NEMA Standards	NEMA TS 4 Section 2 Environmental Requirements
Critical Components	Located in equipment cabinet

## Power Specifications

Model	# of LED panels	Viewing Angle (HxV)	Amps Per Leg	Typical Power <sup>1</sup>
VM-1020-24x48-20-RGB	1	30° x 30°	16	220 W

## Sample Character Capacity

Character Height	Characters	Character Spacing	Example Font Size
9"	1/5	2	12x8_2
12	1/3	3	15x10_2
18	1/2	4	23x15_3

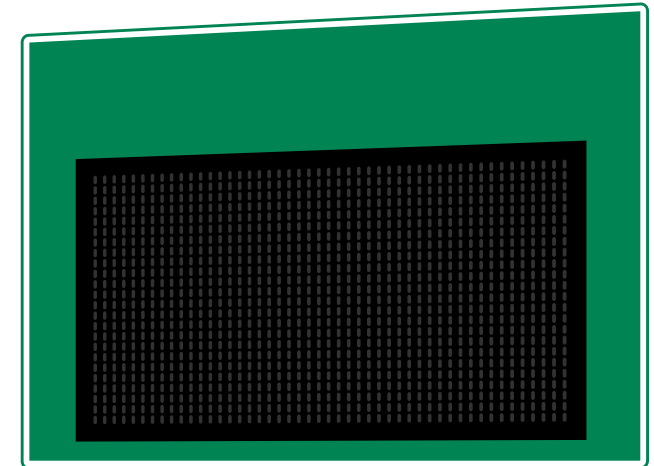

## NOTES

1. Typical power includes a partially-illuminated LED sign (38% of the pixels at full intensity) and the sign controller. For any other site configuration contact Daktronics.
2. VM-1020 Site Power Requirements include required 120/240 VAC 3-wires plus ground to equipment cabinet.
3. Sign front face paint color is semi-gloss black. Other sides are mill finish aluminum.
4. With the continuous improvement of all Daktronics products, the features and measurements on this page are subject to change without notice.
5. The product illustration on this page is for conceptual purposes only and may not represent the actual dimensions of the specified display.
6. 24VDC from equipment cabinet to sign required - see Daktronics riser diagram.



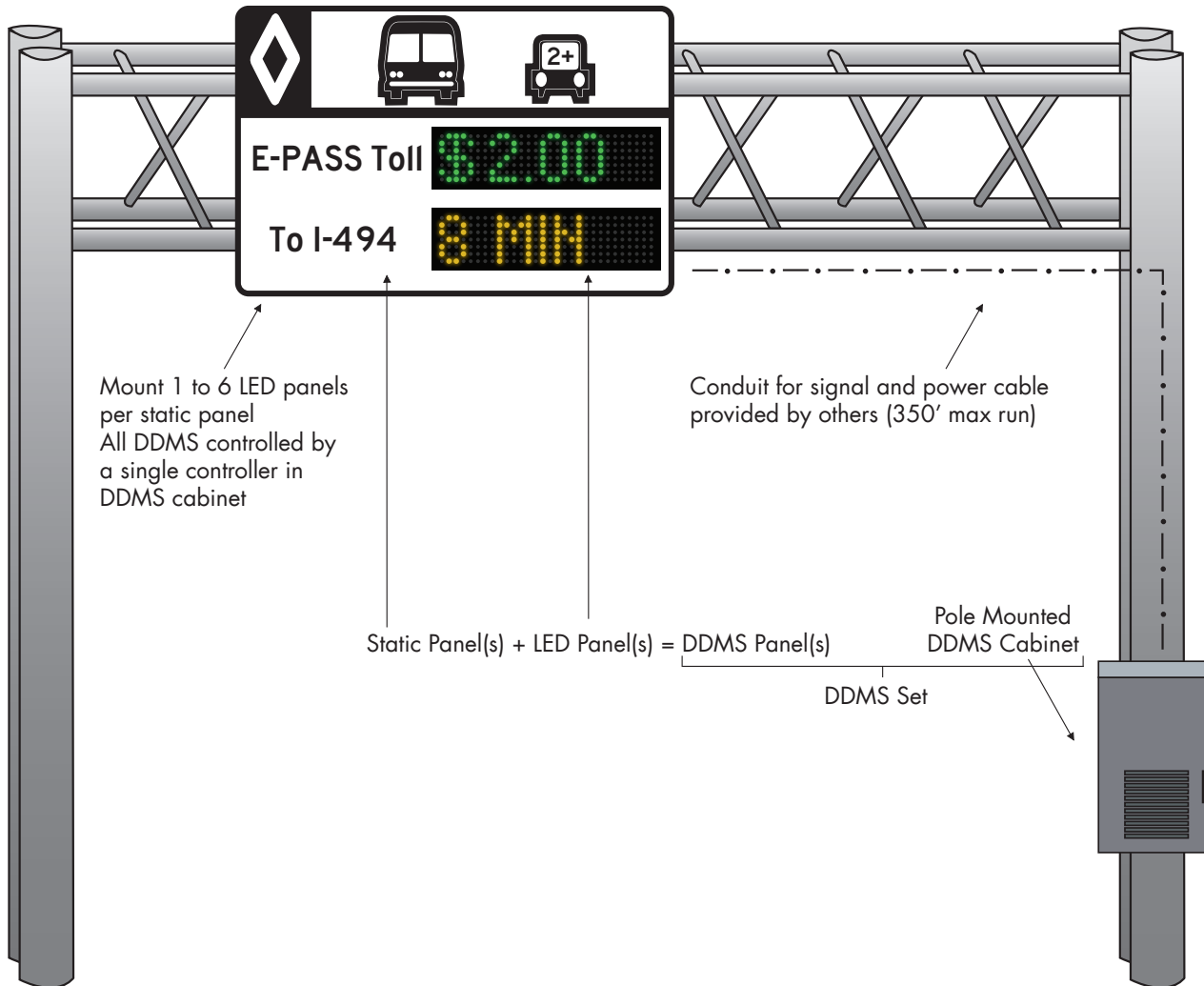

## VM-1020 DDMS Parameters

- › A DDMS set includes: 1 - 6 LED panel(s) and a DDMS cabinet
- › Multiple LED panels can be mounted to a single or multiple static panels
- › Multiple lines require multiple LED panels
- › LED panels are flexible in their ability to be aligned and oriented to static text on the static panel
- › Each LED panel employs a single line matrix
- › Max power cable run is 350' from farthest LED panel to DDMS cabinet
- › All LED panels must be the same matrix width
- › Toll, travel time and status information can be intermixed and displayed on multiple LED panels within a set

## Optional Equipment

Mounting Kit

For additional configuration options, contact Daktronics.

# VANGUARD® VM-1020-24x192-20-RGB

Full-Color (RGB)

## Power Specifications

Model	# of LED panels	Viewing Angle (HxV)	Amps Per Leg	Typical Power <sup>1</sup>
VM-1020-24x192-20-RGB	1	30° x 30°	16	388 W

## Sample Character Capacity

Character Height	Characters	Character Spacing	Example Font Size
9"	1/19	2	12x8_2
12	1/14	3	15x10_2
18	1/10	4	23x15_3

Display Technology	High-intensity LED
Cabinet Access	Front access
Cabinet Enclosure	NEMA 3R
Face Panel	Aluminum mask over polycarbonate face panel
Weight	232 lbs.
Dimensions	1'11" x 13'4" x 5"
Operating Temp. Range	-30° F to +165° F (-34° C to +74° C)
Humidity Range	0 to 99%, non-condensing
Controller Location	Equipment cabinet
Display Type	Full-matrix (variable text and graphics)
Active Area	1'8" x 13'1"
Top/Sides Border Width	1.625" (41 mm)
Bottom Border Width	1" (26 mm)
Pixel Matrix	24 rows x 192 columns
Pixel Pitch	20mm (.81")
Viewing Distance	1100' using 18" characters
Sign Intensity	12,400 candelas/m <sup>2</sup> minimum (white)
LED Color	Full color (32,000 distinct colors using red, green and blue LEDs)
Site Power Requirements <sup>2</sup>	120/240 VAC, single-phase power (3-wires plus ground)
Sign Power Requirements <sup>6</sup>	24 VDC
Communications Protocol	NTCIP 1203 v02
Communications Options	Cellular, fiber optic, direct Ethernet and radio Ethernet
Structural Design Standard	AASHTO
NEMA Standards	NEMA TS 4 Section 2 Environmental Requirements
Critical Components	Located in equipment cabinet

## NOTES

1. Typical power includes a partially-illuminated LED sign (38% of the pixels at full intensity) and the sign controller. For any other site configuration contact Daktronics.
2. VM-1020 Site Power Requirements include required 120/240 VAC 3-wires plus ground to equipment cabinet.
3. Sign front face paint color is semi-gloss black. Other sides are mill finish aluminum.
4. With the continuous improvement of all Daktronics products, the features and measurements on this page are subject to change without notice.
5. The product illustration on this page is for conceptual purposes only and may not represent the actual dimensions of the specified display.
6. 24VDC from equipment cabinet to sign required - see Daktronics riser diagram.



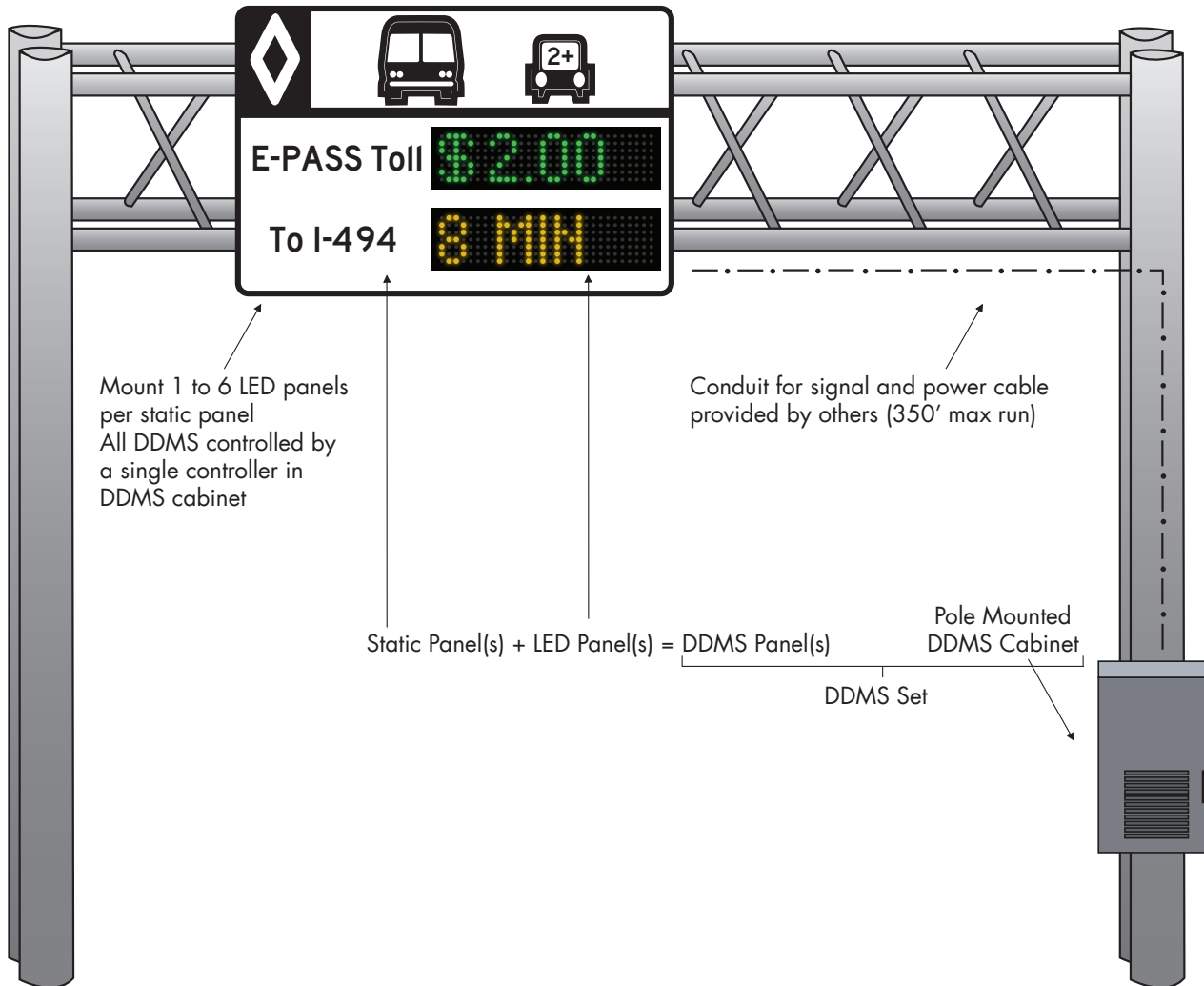

## VM-1020 DDMS Parameters

- › A DDMS set includes: 1 - 6 LED panel(s) and a DDMS cabinet
- › Multiple LED panels can be mounted to a single or multiple static panels
- › Multiple lines require multiple LED panels
- › LED panels are flexible in their ability to be aligned and oriented to static text on the static panel
- › Each LED panel employs a single line matrix
- › Max power cable run is 350' from farthest LED panel to DDMS cabinet
- › All LED panels must be the same matrix width
- › Toll, travel time and status information can be intermixed and displayed on multiple LED panels within a set

## Optional Equipment

Mounting Kit

For additional configuration options, contact Daktronics.

# VANGUARD® VM-1020-24x224-20-RGB

Full-Color (RGB)

## Power Specifications

Model	# of LED panels	Viewing Angle (HxV)	Amps Per Leg	Typical Power <sup>1</sup>
VM-1020-24x224-20-RGB	1	30° x 30°	16	422 W

## Sample Character Capacity

Character Height	Characters	Character Spacing	Example Font Size
9"	1/22	2	12x8_2
12	1/17	3	15x10_2
18	1/12	4	23x15_3

Display Technology	High-intensity LED
Cabinet Access	Front access
Cabinet Enclosure	NEMA 3R
Face Panel	Aluminum mask over polycarbonate face panel
Weight	265 lbs.
Dimensions	1'11" x 15'6" x 5"
Operating Temp. Range	-30° F to +165° F (-34° C to +74° C)
Humidity Range	0 to 99%, non-condensing
Controller Location	Equipment cabinet
Display Type	Full-matrix (variable text and graphics)
Active Area	1'8" x 15'3"
Top/Sides Border Width	1.625" (41 mm)
Bottom Border Width	1" (26 mm)
Pixel Matrix	24 rows x 224 columns
Pixel Pitch	20mm (.81")
Viewing Distance	1100' using 18" characters
Sign Intensity	12,400 candelas/m <sup>2</sup> minimum (white)
LED Color	Full color (32,000 distinct colors using red, green and blue LEDs)
Site Power Requirements <sup>2</sup>	120/240 VAC, single-phase power (3-wires plus ground)
Sign Power Requirements <sup>6</sup>	24 VDC
Communications Protocol	NTCIP 1203 v02
Communications Options	Cellular, fiber optic, direct Ethernet and radio Ethernet
Structural Design Standard	AASHTO
NEMA Standards	NEMA TS 4 Section 2 Environmental Requirements
Critical Components	Located in equipment cabinet

## NOTES

1. Typical power includes a partially-illuminated LED sign (38% of the pixels at full intensity) and the sign controller. For any other site configuration contact Daktronics.
2. VM-1020 Site Power Requirements include required 120/240 VAC 3-wires plus ground to equipment cabinet.
3. Sign front face paint color is semi-gloss black. Other sides are mill finish aluminum.
4. With the continuous improvement of all Daktronics products, the features and measurements on this page are subject to change without notice.
5. The product illustration on this page is for conceptual purposes only and may not represent the actual dimensions of the specified display.
6. 24VDC from equipment cabinet to sign required - see Daktronics riser diagram.

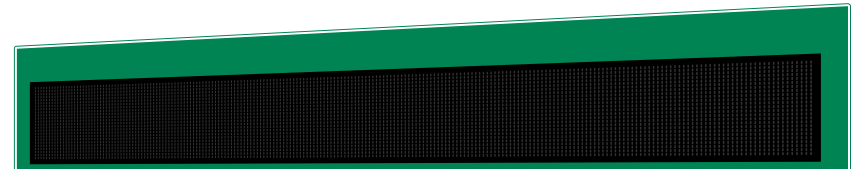

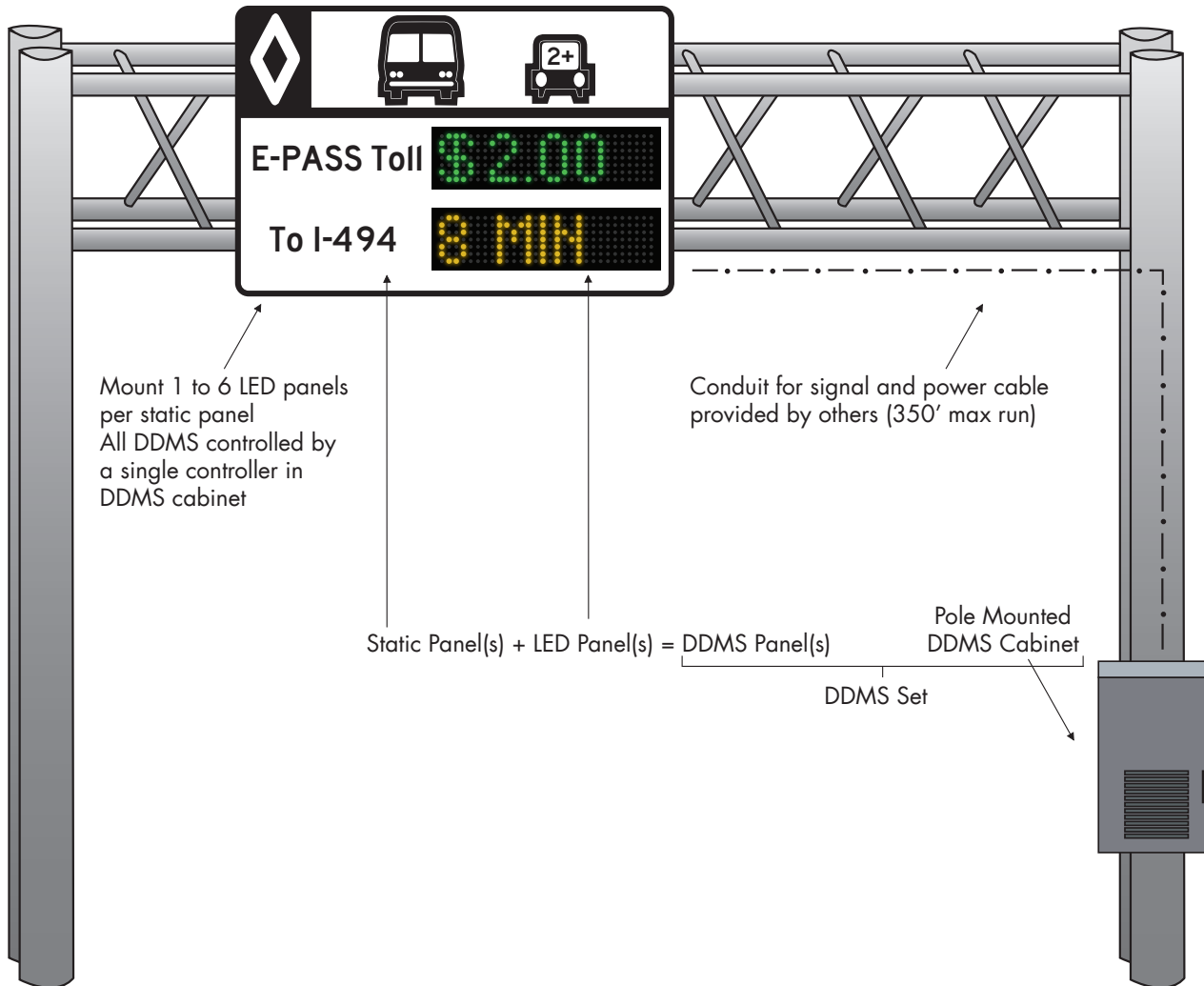

## VM-1020 DDMS Parameters

- › A DDMS set includes: 1 - 6 LED panel(s) and a DDMS cabinet
- › Multiple LED panels can be mounted to a single or multiple static panels
- › Multiple lines require multiple LED panels
- › LED panels are flexible in their ability to be aligned and oriented to static text on the static panel
- › Each LED panel employs a single line matrix
- › Max power cable run is 350' from farthest LED panel to DDMS cabinet
- › All LED panels must be the same matrix width
- › Toll, travel time and status information can be intermixed and displayed on multiple LED panels within a set

## Optional Equipment

Mounting Kit

For additional configuration options, contact Daktronics.

# VANGUARD® VM-1020-24x288-20-RGB

Full-Color (RGB)

## Power Specifications

Model	# of LED panels	Viewing Angle (HxV)	Amps Per Leg	Typical Power <sup>1</sup>
VM-1020-24x288-20-RGB	1	30° x 30°	16	501 W

## Sample Character Capacity

Character Height	Characters	Character Spacing	Example Font Size
9"	1/29	2	12x8_2
12	1/22	3	15x10_2
18	1/15	4	23x15_3

Display Technology	High-intensity LED
Cabinet Access	Front access
Cabinet Enclosure	NEMA 3R
Face Panel	Aluminum mask over polycarbonate face panel
Weight	330 lbs.
Dimensions	1'11" x 19'10" x 5"
Operating Temp. Range	-30° F to +165° F (-34° C to +74° C)
Humidity Range	0 to 99%, non-condensing
Controller Location	Equipment cabinet
Display Type	Full-matrix (variable text and graphics)
Active Area	1'8" x 19'7"
Top/Sides Border Width	1.625" (41 mm)
Bottom Border Width	1" (26 mm)
Pixel Matrix	24 rows x 288 columns
Pixel Pitch	20mm (.81")
Viewing Distance	1100' using 18" characters
Sign Intensity	12,400 candelas/m <sup>2</sup> minimum (white)
LED Color	Full color (32,000 distinct colors using red, green and blue LEDs)
Site Power Requirements <sup>2</sup>	120/240 VAC, single-phase power (3-wires plus ground)
Sign Power Requirements <sup>6</sup>	24 VDC
Communications Protocol	NTCIP 1203 v02
Communications Options	Cellular, fiber optic, direct Ethernet and radio Ethernet
Structural Design Standard	AASHTO
NEMA Standards	NEMA TS 4 Section 2 Environmental Requirements
Critical Components	Located in equipment cabinet

## NOTES

1. Typical power includes a partially-illuminated LED sign (38% of the pixels at full intensity) and the sign controller. For any other site configuration contact Daktronics.
2. VM-1020 Site Power Requirements include required 120/240 VAC 3-wires plus ground to equipment cabinet.
3. Sign front face paint color is semi-gloss black. Other sides are mill finish aluminum.
4. With the continuous improvement of all Daktronics products, the features and measurements on this page are subject to change without notice.
5. The product illustration on this page is for conceptual purposes only and may not represent the actual dimensions of the specified display.
6. 24VDC from equipment cabinet to sign required - see Daktronics riser diagram.



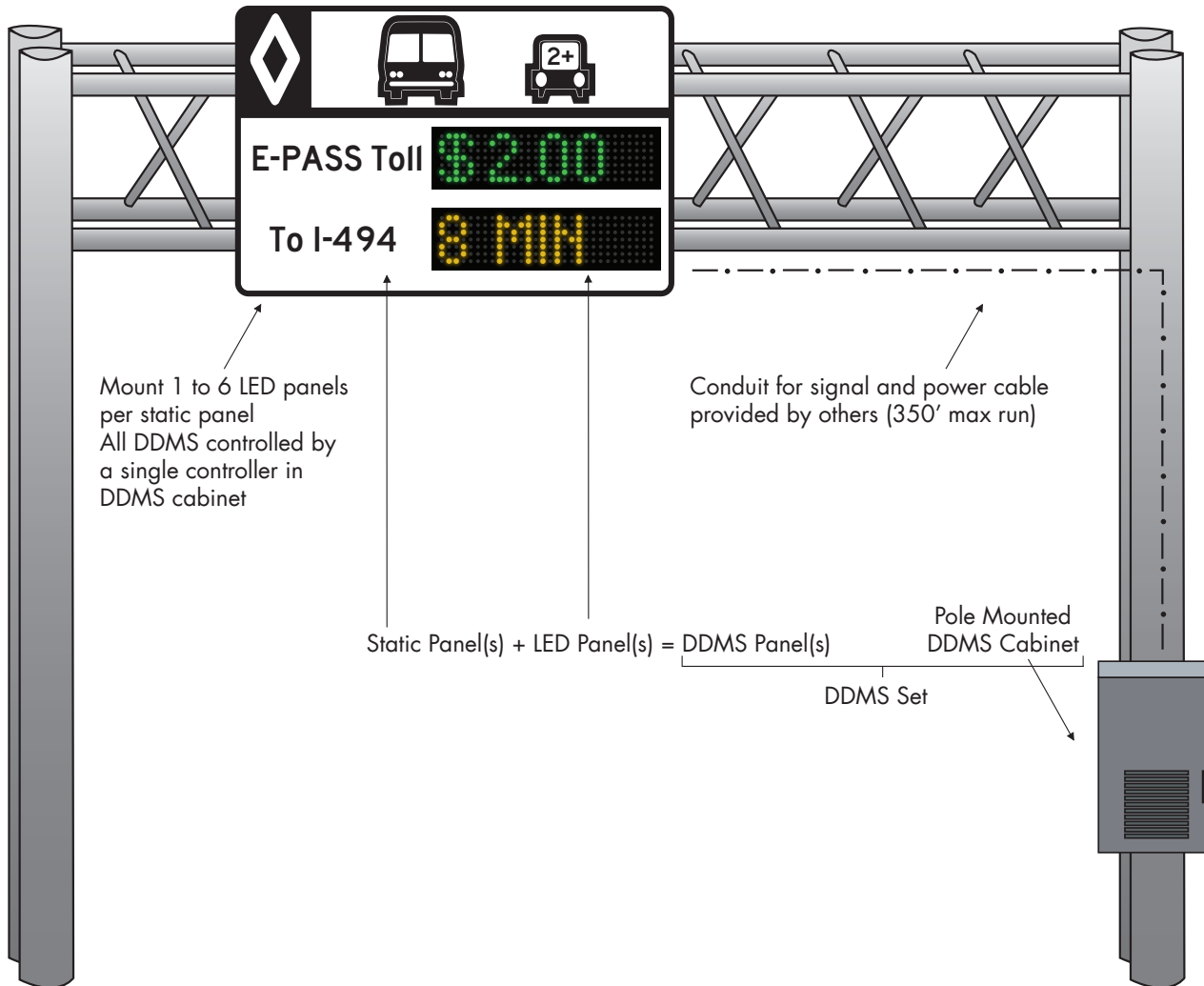

## VM-1020 DDMS Parameters

- › A DDMS set includes: 1 - 6 LED panel(s) and a DDMS cabinet
- › Multiple LED panels can be mounted to a single or multiple static panels
- › Multiple lines require multiple LED panels
- › LED panels are flexible in their ability to be aligned and oriented to static text on the static panel
- › Each LED panel employs a single line matrix
- › Max power cable run is 350' from farthest LED panel to DDMS cabinet
- › All LED panels must be the same matrix width
- › Toll, travel time and status information can be intermixed and displayed on multiple LED panels within a set

## Optional Equipment

Mounting Kit

For additional configuration options, contact Daktronics.

# VANGUARD® VX-2428-32x48-20-RGB

Full-Color (RGB)

## Power Specifications

Display Technology	High-intensity LED
Cabinet Access	Front access
Cabinet Enclosure	NEMA 3R
Face Panel	Aluminum mask over polycarbonate face panel
Weight	73 lbs. (34 kg)
Dimensions <sup>1</sup>	2'7" H x 3'6" W x 5" D (.73 m H x 1.1 m W x .13 m D)
Operating Temp. Range	-30° F to +165° F (-34° C to +74° C)
Humidity Range	0 to 99%, non-condensing
Controller Location	Equipment cabinet
Display Type	Full-matrix (variable text and graphics)
Active Area	2'2" H x 3'2" W (.66 m H x .99 m W)
Top/Bottom Border Width	4" (101 mm)
Left/Right Border Width	4" (101 mm)
Pixel Matrix	32 rows x 48 columns
Pixel Pitch	20mm (.81")
Viewing Distance	300' (91 m) using 6" characters
Sign Intensity	12,400 candelas/m <sup>2</sup> minimum (white)
LED Color	Full color (32,000 distinct colors using red, green and blue LEDs)
Site Power Requirements <sup>5</sup>	120/240 VAC, single-phase power (3-wires plus ground)
Sign Power Requirements <sup>9</sup>	24 VDC
Communications Protocol	NTCIP 1203
Communications Options	Cellular, Serial, Ethernet
Structural Design Standard	AASHTO
NEMA Standards	NEMA TS 4 Section 2 Environmental Requirements
Critical Components	Located in equipment cabinet

Model	Quantity	Viewing Angle (HxV)	Amps Per Leg <sup>3</sup>	Typical Power <sup>4</sup>
VX-2428-32x48-20-RGB	1	30° x 30°	16	268 W
	2		16	378 W
	3		16	488 W
	4		16	598 W
	5		16	710 W
	6		18	830 W
	7		20	950 W
	8		22	1070 W

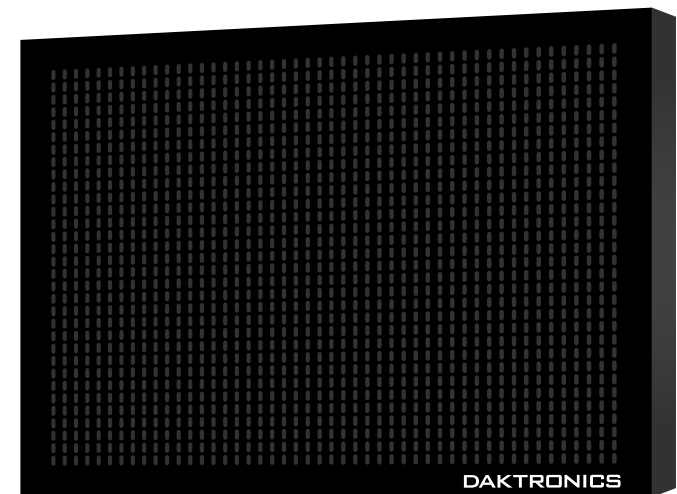

### NOTES

1. Display cabinet depth measurement includes "Z" mounting brackets on the rear of the cabinet.
2. Many other font sizes are available.
3. Please contact Daktronics for site-specific power requirements.
4. Typical power includes a partially-illuminated LED sign (38% of the pixels at full intensity) and the sign controller.
5. VX-2428 Site Power Requirements include required 120/240 VAC 3-wires plus ground to equipment cabinet.
6. Sign front face paint color is semi-gloss black. Other sides are mill finish aluminum.
7. With the continuous improvement of all Daktronics products, the features and measurements on this page are subject to change without notice.
8. The product illustration on this page is for conceptual purposes only and may not represent the actual dimensions of the specified display.
9. 24VDC from equipment cabinet to sign required - see Daktronics riser diagram.



The RuggedSwitch™ RS900G is an industrially hardened, fully managed Ethernet switch providing dual fiber optical Gigabit Ethernet ports and eight Fast Ethernet copper ports.

Designed to operate reliably in harsh industrial environments the RS900G provides a high level of immunity to electromagnetic interference and heavy electrical surges typical of environments found in electric utility substations, factory floors or in curb side traffic control cabinets. An operating temperature range of -40°C to +85°C coupled with hazardous location certification, optional conformal coating and a galvanized steel enclosure allows the RS900G to be placed in almost any location.

The embedded Rugged Operating System (ROS™) provides advanced networking features such as Enhanced Rapid Spanning Tree (eRSTP™), Port Rate Limiting and a full array of intelligent functionality for high network availability and manageability.

The versatility and wide selection of fiber optics allows the RS900G to be used in a variety of applications. The RS900G provides two fiber optical Gigabit Ethernet ports for creating a fiber optical backbone with high noise immunity and long haul connectivity.

The embedded Rugged Operating System (ROS™) provides advanced layer 2 and layer 3 networking functions, and advanced cyber security features. Coupled with the ruggedized hardware design, RS900G is ideal for creating mission-critical, real-time, control applications where high reliability and availability is of paramount importance.

## Features and Benefits

### Ethernet Ports

- 2 - Fiber Optical Gigabit Ethernet Ports (1000BaseX)
- 8 - Fast Ethernet Ports (10/100BaseTX)
- Multiple fiber connector types (LC, SC, SFP Pluggable Optics)
- Bi-directional singlestrand fiber support
- Long haul optics allow Gigabit distances up to 70km

### Cyber Security Features

- Multi-level user passwords
- SSH/SSL encryption
- Enable/disable ports, MAC based port security
- Port based network access control (802.1x)
- VLAN (802.1q ) to segregate and secure network traffic
- Radius centralized password management
- SNMPv3 encrypted authentication and access security

### RuggedRated™ for Reliability in Harsh Environments

- Immunity to EMI and heavy electrical surges
  - Meets IEEE 1613 (electric utility substations)
  - Exceeds IEC 61850-3 (electric utility substations)
  - Exceeds IEEE 61800-3 (variable speed drive systems)
  - Exceeds IEC 61000-6-2 (generic industrial)
  - Exceeds NEMA TS-2 (traffic control equipment)
- Hazardous Location Certification: Class 1 Division 2
- -40 to +85°C operating temperature (no fans)
- Conformal coated printed circuit boards (optional)

### Rugged Operating System (ROS™) Features

- Simple plug and play operation - automatic learning, negotiation, and crossover detection
- RSTP (802.1w) and Enhanced Rapid Spanning Tree (eRSTP™) network fault recovery (<5ms)
- Quality of Service (802.1p) for real-time traffic
- VLAN (802.1q) with double tagging and GVRP support
- Link aggregation (802.3ad)
- IGMP Snooping for multicast filtering
- Port Rate Limiting and Broadcast Storm Limiting
- Port configuration, status, statistics, mirroring, security
- Industrial automation features (eg. Modbus)

### Management Tools

- Web-based, Telnet, CLI management interfaces
- SNMP v1/v2/v3
- Remote Monitoring (RMON)
- Rich set of diagnostics with logging and alarms

### Universal Power Supply Options

- Fully integrated power supply
- Universal high-voltage range: 88-300VDC or 85-264VAC
- Dual low-voltage DC inputs: 24VDC (9-36VDC) or 48VDC (36-59VDC)
- Terminal blocks for reliable maintenance free connections
- CSA/UL 60950 safety approved to +85°C



# RuggedSwitch™ RS900G

### Dual Gigabit Ports:

- ▶ Pluggable Optics (SFP)
- ▶ LC or SC connectors
- ▶ Bi-directional (single strand)
- ▶ Distances up to 70km

### Rugged Construction:

- ▶ 20 AWG. galvanized steel enclosure
- ▶ Conformal coating (optional)

### Hazardous Location Certification

- ▶ Class1, Division2

### Integrated Power Supply

- ▶ Universal high-voltage range: 88-300VDC or 85 - 264VAC
- ▶ Popular low voltage DC ranges: 24VDC (9-36VDC), 48VDC (36-59VDC)
- ▶ Dual Isolated DC power inputs

### Mounting Options

- ▶ Din Rail
- ▶ Panel Mount

### Operating Temperature

- ▶ -40°C to +85°C
- ▶ No Fans

### Fast Ethernet Ports:

- ▶ 8 - Fast Ethernet Ports (10/100BaseTX)

### Critical Alarm Relay

- ▶ Form-C failsafe contact relay: 1A@30VDC

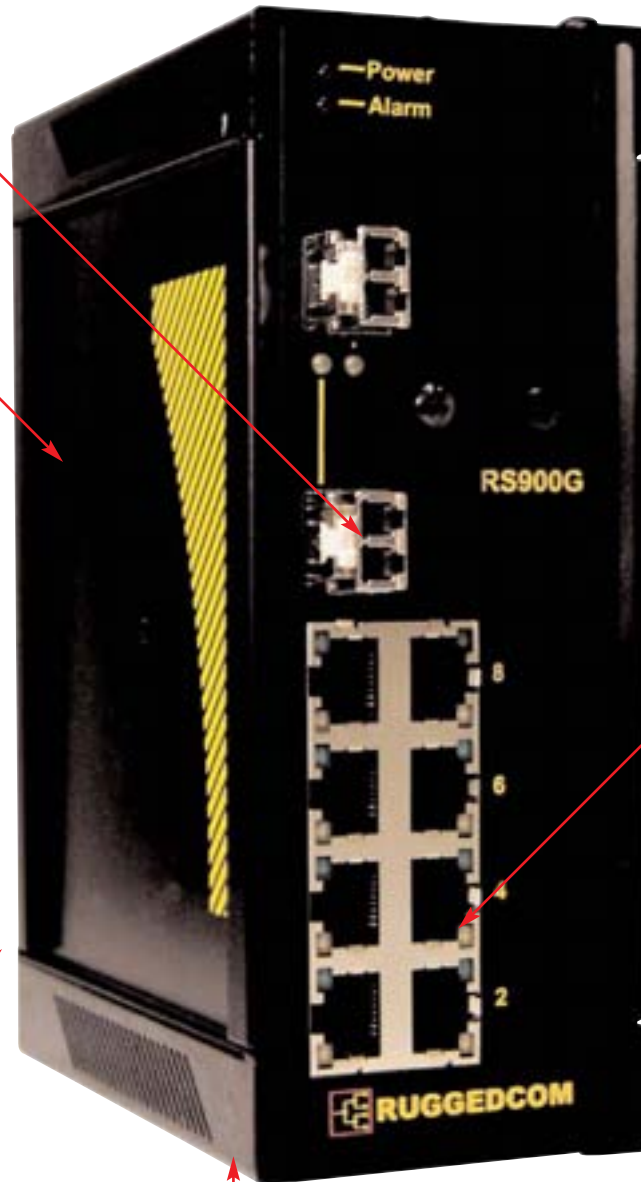

## ROS™ Features

### Cyber Security

Cyber security is an urgent issue in many industries where advanced automation and communications networks play a crucial role in mission critical applications and where high reliability is of paramount importance. Key ROS™ features that address security issues at the local area network level include:

- **Passwords** - Multi-level user passwords secures switch against unauthorized configuration
- **SSH / SSL** - Extends capability of password protection to add encryption of passwords and data as they cross the network
- **Enable / Disable Ports** - Capability to disable ports so that traffic can not pass
- **802.1q VLAN** - Provides the ability to logically segregate traffic between predefined ports on switches
- **MAC Based Port Security** - The ability to secure ports on a switch so only specific Devices / MAC addresses can communicate via that port
- **802.1x Port Based Network Access Control** - The ability to lock down ports on a switch so that only authorized clients can communicate via this port
- **Radius** - Provides centralized password management
- **SNMPv3** - encrypted authentication and access security

The ROS™ cyber security features are included to help address the various industry specific security standards such as NERC CIP, ISA S99, AGA 12, IEC 62443, ISO 17799:2005 and PCSRF SPP-ICS.

### Enhanced Rapid Spanning Tree Protocol (eRSTP™)

RuggedCom eRSTP allows the creation of fault-tolerant ring and mesh Ethernet networks that incorporate redundant links that are 'pruned' to prevent loops. eRSTP yields worst-case fault recovery<sup>1</sup> of 5ms times the 'bridge diameter' and allows rings of up to 80 switches. For example, a ring of ten switches will have fault recovery times under 50ms. eRSTP implements both STP and RSTP to ensure interoperability with commercial switches unlike other proprietary 'ring' solutions.

### Quality of Service (IEEE 802.1p)

Some networking applications such as real-time control or VoIP (voice over IP) require predictable arrival times for Ethernet frames. Switches can introduce latency in times of heavy network traffic due to the internal queues that buffer frames and then transmit on a first come first serve basis. ROS™ supports 'Class of Service' in accordance with IEEE 802.1p that allows time critical traffic to jump ahead to the front of the queue thus minimizing latency and reducing jitter to allow such demanding applications to operate correctly. ROS™ allows priority classification by port, tags, MAC address, and IP type of service (TOS).

A configurable "weighted fair queuing" algorithm controls how frames are emptied from the queues.

### VLAN (IEEE 802.1q)

Virtual local area networks (VLAN) allow the segregation of a physical network into separate logical networks with independent broadcast domains. A measure of security is provided since hosts can only access other hosts on the same VLAN and traffic storms are isolated. ROS™ supports 802.1q tagged Ethernet frames and VLAN trunks. Port based classification allows legacy devices to be assigned to the correct VLAN. GVRP support is also provided to simplify the configuration of the switches on the VLAN.

### Link Aggregation (802.3ad)

The link aggregation feature provides the ability to aggregate several Ethernet ports into one logical link (port trunk) with higher bandwidth. This provides an inexpensive way to set up a high speed backbone to improve network bandwidth. This feature is also known as "port trunking", "port bundling", "port teaming", and "ethernet trunk".

### IGMP Snooping

ROS uses IGMP snooping (Internet Group Management Protocol v1&v2) to intelligently forward or filter multicast traffic streams (e.g. MPEG video) to or from hosts on the network. This reduces the load on network trunks and prevents packets from being received on hosts that are not involved. ROS™ has a very powerful implementation of IGMP snooping that:

- Can be enabled on a per VLAN basis.
- Detects and filters all multicast streams regardless of whether subscribers exist.
- Supports "router-less" operation by supporting an "active" mode.
- Restores traffic streams immediately after an RSTP topology change.

### SNMP (Simple Network Management Protocol)

SNMP provides a standardized method for network management stations the ability to interrogate devices from different vendors. SNMP versions supported by ROS™ are v1, v2c, and v3. SNMPv3 in particular provides security features (such as authentication, privacy, and access control) not present in earlier SNMP versions. ROS™ also supports numerous standard MIBs (Management Information Base) allowing for easy integration with any network management system (NMS).

<sup>1</sup> eRSTP fault recovery times may be approximated as follows:

For 100 Mbps, fault recovery performance is <5ms/hop

For 1,000 Mbps, fault recovery performance is <5ms/hop + 20ms

## ROS™ Features

### **SNMP (Simple Network Management Protocol) (cont'd)**

A feature of SNMP supported by ROS™ is the ability to generate "traps" upon system events. A NMS can record traps from multiple devices providing a powerful network troubleshooting tool. RuggedVue™ is RuggedCom's NMS that provides graphical visualization of the network and is fully integrated with all RuggedCom products.

### **SNTP (Simple Network Time Protocol)**

SNTP automatically synchronizes the internal clock of all ROS™ devices on the network. This allows for correlation of time stamped events for troubleshooting.

### **SCADA and Industrial Automation**

ROS™ contains features that optimize network performance and simplify switch management based on the unique requirements found in SCADA and industrial automation applications. Features such as Modbus TCP management for retrieval of switch data using the ubiquitous Modbus protocol and DHCP Option 82, a Rockwell Automation ODVA requirement for IP address assignment based on the location of the end device, provide capabilities not found in typical "commercial" or "office grade" Ethernet switches.

### **Port Based Network Access Control (802.1x)**

ROS™ supports the IEEE 802.1x standard that defines a mechanism for port-based network access control which provides a means of authenticating and authorizing devices attached to LAN ports.

### **Port Rate Limiting**

ROS™ supports configurable rate limiting per port to limit unicast and multicast traffic. This can be essential to managing precious network bandwidth for service providers. It also provides edge security for denial of service (DOS) attacks.

### **Broadcast Storm Filtering**

Broadcast storms wreak havoc on a network and can cause attached devices to malfunction. This could be disastrous on a network with mission critical equipment. ROS™ limits this by filtering broadcast frames with a user-defined threshold.

### **Loss of Link Management**

Some intelligent electronic devices (IEDs) have dual fiber optic ports with automatic failover to a backup port should the primary fail. ROS™ ensures this mechanism works reliably under all failure modes by appropriately disabling link signals when required. ROS™ also flushes learned MAC addresses to ensure the failover occurs quickly.

### **Port Mirroring**

ROS™ can be configured to duplicate all traffic on one port to a designated mirror port. When combined with a network analyzer, this can be a powerful troubleshooting tool.

### **Port Configuration and Status**

ROS™ allows individual ports to be 'hard' configured for speed, duplex, auto-negotiation, flow control and more. This allows proper connection with devices that do not negotiate or have unusual settings. Detailed status of ports with alarm and SNMP trap on link problems aid greatly in system troubleshooting.

### **Port Statistics and RMON (Remote Monitoring)**

ROS™ provides continuously updating statistics per port that provide both ingress and egress packet and byte counters as well as detailed error figures. Also provided is full support for the RMON statistics, history, alarms, and event groups. RMON allows for very sophisticated data collection, analysis and detection of traffic patterns.

### **Event Logging and Alarms**

ROS™ records all significant events to a non-volatile system log allowing forensic troubleshooting. Events include link failure and recovery, unauthorized access, broadcast storm detection, and self-test diagnostics among others. Alarms provide a snapshot of recent events that have yet to be acknowledged by the network administrator. An external hardware relay is de-energized during the presence of critical alarms allowing an external controller to react if desired.

### **HTML Web Browser and Telnet User Interfaces**

ROS™ provides a simple, intuitive user interface for configuration and monitoring via a standard graphical web browser or via Telnet. All system parameters include detailed on-line help to make setup a breeze. ROS™ , presents a common look and feel and standardized configuration process allowing easy migration to other RuggedCom managed products.

### **Configuration via ASCII Text File**

All configuration parameters are stored in an ASCII formatted text file that can easily be transferred via TFTP or Xmodem. The configuration file can be saved for backup purposes and easily manipulated by a text editor. The same text file can be downloaded to the switch at a later date in order to re-configure or restore a previous configuration.

### **Command Line Interface (CLI)**

A command line interface can be used in conjunction with remote shell to automate data retrieval, configuration updates, and firmware upgrades. A powerful SQL-like capability allows expert users the ability to selectively retrieve or manipulate any parameters the device has to offer.

# EMI and Environmental Type Tests

IEC 61850-3 EMI TYPE TESTS				
TEST	Description		Test Levels	Severity Levels
IEC 61000-4-2	ESD	Enclosure Contact	+/- 8kV	4
		Enclosure Air	+/- 15kV	4
IEC 61000-4-3	Radiated RFI	Enclosure ports	20 V/m	x
IEC 61000-4-4	Burst (Fast Transient)	Signal ports	+/- 4kV @ 2.5kHz	x
		D.C. Power ports	+/- 4kV	4
		A.C. Power ports	+/- 4kV	4
		Earth ground ports <sup>3</sup>	+/- 4kV	4
IEC 61000-4-5	Surge	Signal ports	+/- 4kV line-to-earth, +/- 2kV line-to-line	4
		D.C. Power ports	+/- 2kV line-to-earth, +/- 1kV line-to-line	3
		A.C. Power ports	+/- 4kV line-to-earth, +/- 2kV line-to-line	4
IEC 61000-4-6	Induced (Conducted) RFI	Signal ports	10V	3
		D.C Power ports	10V	3
		A.C. Power ports	10V	3
		Earth ground ports <sup>3</sup>	10V	3
IEC 61000-4-8	Magnetic Field	Enclosure ports	40 A/m continuous, 1000 A/m for 1 s	N/A
IEC 61000-4-29	Voltage Dips & Interrupts	D.C. Power ports	30% for 0.1s, 60% for 0.1s, 100% for 0.05s	N/A
IEC 61000-4-11		A.C. Power ports	30% for 1 period, 60% for 50 periods 100% for 5 periods, 100% for 50 periods <sup>2</sup>	N/A
IEC 61000-4-12	Damped Oscillatory	Signal ports	2.5kV common, 1kV diff. mode@1MHz	3
		D.C. Power ports	2.5kV common, 1kV diff. mode@1MHz	3
		A.C. Power ports	2.5kV common, 1kV diff. mode@1MHz	3
IEC 61000-4-16	Mains Frequency Voltage	Signal ports	30V Continuous, 300V for 1s	4
		D.C. Power ports	30V Continuous, 300V for 1s	4
IEC 61000-4-17	Ripple on D.C. Power Supply	D.C. Power ports	10%	3
IEC 60255-5	Dielectric Strength	Signal ports	2kVac (Fail-Safe Relay output)	N/A
		D.C. Power ports	2kVac	N/A
		A.C. Power ports	2kVac	N/A
IEC 60255-5	H.V. Impulse	Signal ports	5kV (Fail-Safe Relay output)	N/A
		D.C. Power ports	5kV	N/A
		A.C. Power ports	5kV	N/A

IEEE 1613 (C37.90.x) EMI IMMUNITY TYPE TESTS				
Test	Description		Test Levels	Severity Levels
IEEE C37.90.3	ESD	Enclosure Contact	+/- 8kV	N/A
		Enclosure Air	+/- 15kV	N/A
IEEE C37.90.2	Radiated RFI	Enclosure ports	35 V/m	N/A
IEEE C37.90.1	Fast Transient	Signal ports	+/- 4kV @ 2.5kHz	N/A
		D.C. Power ports	+/- 4kV	N/A
		A.C. Power ports	+/- 4kV	N/A
		Earth ground ports <sup>3</sup>	+/- 4kV	N/A
IEEE C37.90.1	Oscillatory	Signal ports	2.5kV common mode @1MHz	N/A
		D.C. Power ports	2.5kV common, 1kV diff. mode@1MHz	N/A
		A.C. Power ports	2.5kV common, 1kV diff. mode@1MHz	N/A
IEEE C37.90	H.V. Impulse	Signal ports	5kV (Fail-Safe Relay output)	N/A
		D.C. Power ports	5kV	N/A
		A.C. Power ports	5kV	N/A
IEEE C37.90	Dielectric Strength	Signal ports	2kVac	N/A
		D.C. Power ports	2kVac	N/A
		A.C. Power ports	2kVac	N/A

Environmental Type Tests				
Test	Description		Test Levels	Severity Levels
IEC 60068-2-1	Cold Temperature	Test Ad	-40°C, 16 Hours	N/A
IEC 60068-2-2	Dry Heat	Test Bd	+85°C, 16 Hours	N/A
IEC 60068-2-30	Humidity (Damp Heat, Cyclic)	Test Db	95% (non-condensing), 55°C, 6 cycles	N/A
IEC 60255-21-1	Vibration	Tests Fc	2g @ (10 - 150) Hz	Class 2
IEC 60255-21-2	Shock	Tests Ea	30g @ 11mS	Class 2

Notes: 1. Only applicable to functional earth connections separated from the safety earth connection.  
 2. Class 2 refers to "Measuring relays and protection equipment for which a very high security margin is required or where the vibration levels are very high, (e.g. shipboard application and for severe transportation conditions)"

## Technical Specifications

### Power Supply

- Power Consumption: 10W Max
- 24VDC: 9-36 VDC, 0.4A
- 48VDC: 36-59 VDC, 0.2A
- HI Voltage AC/DC: 88-300VDC or 85-264VAC

### Critical Alarm Relay

- Form-C failsafe contact relay: 1A@30VDC

### Physical

- Height: 7.4"
- Width: 2.6"
- Depth: 5.0"
- Weight: 2.7lbs
- Ingress Protection: IP40 (1mm objects)
- Enclosure: 20 AWG galvanized steel enclosure
- Mounting: DIN rail or panel mounted

### Switch Properties

- Switching method: Store & Forward
- Switching latency: 7 us
- Switching bandwidth: 5.6Gbps
- MAC addresses: 4096
- MAC address table size: 32kbytes
- Priority Queues: 4
- Frame buffer memory: 2 Mbit
- VLANs: 4096
- IGMP multicast groups: 256
- Port rate limiting: 128kbps, 256, 512, 4, 8Mbps
- No head of line blocking

### Approvals

- Hazardous Locations: Class 1, Division 2
- ISO: Designed and manufactured using a ISO9001: 2000 certified quality program
- CE Marking
- Emissions: FCC Part 15 (Class A), EN55022 (CISPR22 Class A)
- Safety: cCSAus (Compliant with CSA C22.2 No. 60950, UL 60950, EN60950)
- Laser Eye Safety (FDA/CDRH): Complies with 21 CFR Chapter1, Subchapter J.

### Warranty

- 5 Years - Applicable to design and manufacturing related product defects.

### Network Management

- HTTP graphical web-based
- SNMP v1, v2c, v3
- Telnet, VT100
- Command Line Interface (CLI)

### EMI Immunity and Environmental Compliance

- IEC 61000-6-2 Industrial (Generic)
- IEC 61800-3 Industrial (Variable Speed Drive Systems)
- IEC 61850-3 Electric Utility Substations
- IEEE 1613 Electric Utility Substations
- NEMA TS 2 Traffic Control Equipment (pending)

### IEEE Compliance

- 802.3-10BaseT
- 802.3u-100BaseTX, 100BaseFX
- 802.3x-Flow Control
- 802.3z-1000BaseLX
- 802.3ab-1000BaseTX
- 802.3ad-Link Aggregation
- 802.1d-MAC Bridges
- 802.1d-Spanning Tree Protocol
- 802.1p-Class of Service
- 802.1q-VLAN Tagging
- 802.1w-Rapid Spanning Tree Protocol
- 802.1x-Port Based Network Access Control

### IETF RFC Compliance

- RFC768-UDP
- RFC783-TFTP
- RFC791-IP
- RFC792-ICMP
- RFC793-TCP
- RFC826-ARP
- RFC854-Telnet
- RFC894-IP over Ethernet
- RFC1112-IGMP v1
- RFC1519-CIDR
- RFC1541-DHCP (client)
- RFC2030-SNTP
- RFC2068-HTTP
- RFC2236-IGMP v2
- RFC2284-EAP
- RFC2475-Differentiated Services
- RFC2865-Radius
- RFC3414-SNMPv3-VSM
- RFC3415-SNMPv3-VACM

### IETF SNMP MIBS

- RFC1493-BRIDGE-MIB
- RFC1907-SNMPv2-MIB
- RFC2012-TCP-MIB
- RFC2013-UDP-MIB
- RFC2578-SNMPv2-SMI
- RFC2579-SNMPv2-TC
- RFC2819-RMON-MIB
- RFC2863-IF-MIB
- draft-ietf-bridge-rstpmib-03-BRIDGE-MIB
- draft-ietf-bridge-bridgemib-smiv2-03-RSTP-MIB
- IANAifType-MIB

# Fiber Specifications and Mechanical Drawing

Fiber Optical Specifications					
Parameter	Fiber Port Type				
Mode	Multimode	Singlemode	Singlemode	Singlemode	Singlemode
Connector	LC, LC-SFP	SC, LC, LC-SFP	SC, LC, LC-SFP	LC-SFP	LC-SFP
Typical Dist.	500m	10km	25km	40km	70km
Optical Wavelength (nm)	850	1310	1310	1550	1550
Cable Size Core/Cladding (um)	50/125 or 62.5/125	8/125 or 9/125	8/125 or 9/125	8/125 or 9/125	8/125 or 9/125
TX Power (Min/Max) (dBm)	-9.5/-4	-9/-3	-7 / 3	-6 / 0	0 / 5
RX Sensitivity (dBm)	-20	-22	-26	-23	-23
RX Saturation (dBm)	0	-3	-3	0	0
Typical Budget (dB)	14	17	19	21	25

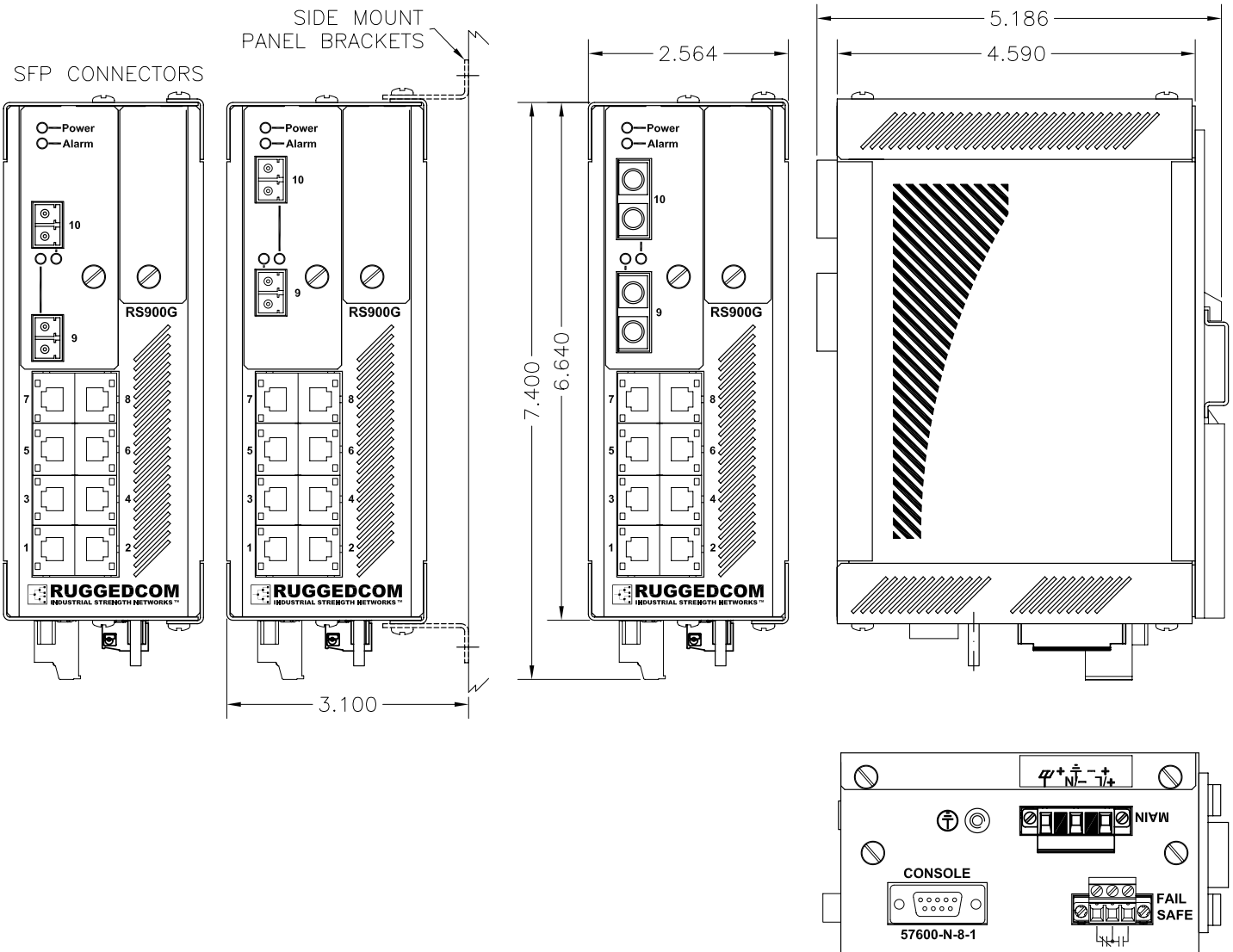

## Order Codes

RS900G - \_ - \_ - \_\_\_\_\_  
PS M P9P10

### PS: Power Supply

- 24 = 24 VDC (9-36 VDC)
- 48 = 48 VDC (36-59 VDC)
- HI = 88-300VDC or 85-264VAC

### M: Mounting Option

- D = DIN Rail
- P = Panel Mount
- N = None

### P9P10 Transceiver Options (2):

- 2SFP = Dual 1000X SFP (Mini-GBIC). Order SFP Optics Separately.
- 2LCMM = Dual 1000SX Multimode LC 850nm 500m
- 2LC10 = Dual 1000LX Singlemode LC 1310nm 10km
- 2LC25 = Dual 1000LX Singlemode LC 1310nm 25km
- 2SC10 = Dual 1000LX Singlemode SC 1310nm 10km
- 2SC25 = Dual 1000LX Singlemode SC 1310nm 25km

### SFP (MINI-GBIC) Transceiver Options (1) (2):

- 25-10-0111 = 1000SX SFP, Multimode, LC, 850nm, 500m (3)
- 25-10-0100 = 1000LX SFP, Singlemode, LC, 1310nm, 10 km
- 25-10-0101 = 1000LX SFP, Singlemode, LC, 1310nm, 25 km
- 25-10-0109 = 1000LX SFP, Singlemode, LC, 1550nm, 70 km (3)

### NOTES

- <sup>1</sup> Distance ratings are typical but will depend on type of cabling, number of connectors and splices.
- <sup>2</sup> Should you not find an appropriate fiber optic option listed here, please consult RuggedCom for other options.
- <sup>3</sup> These transceivers have an operating temperature range of -20 to +85°C. All other transceivers have an operating temperature range of -40° to +85°C.

### Options

82-01-0002 - Conformal Coating

RuggedCom Inc.  
30 Whitmore Road  
Woodbridge, Ontario, Canada L4L 7Z4  
Tel: (905) 856-5288 Fax: (905) 856-1995  
Toll Free: (888) 264-0006  
Technical Support Center: (866) 922-7975 or (954) 922-7975

© 2006 RuggedCom Inc.  
RuggedSwitch is a trademark of RuggedCom Inc.  
Ethernet is a trademark of the Xerox Corporation.  
Patent Pending  
All specifications in this document are subject to change without notice.  
Rev 1-T

For additional information on our products and services, please visit our web site at: [www.ruggedcom.com](http://www.ruggedcom.com)

## 5. Video Wall Specifications



DISPLAY WALL

**SWITCHING**

PIXELSWITCH 16, 24, 48



**SOURCES AND INPUTS**

ANALOG HD SOURCE	PIXELNET HD INPUT
HD SOURCE	
SDI INPUT	PIXELNET SDI INPUT
CAMERA INPUT	
DVI RGB INPUT	PIXELNET DVI INPUT
COMPUTER	

**PIXELNET INPUTS**

**FUSION 980 DISPLAY WALL PROCESSOR**

NETWORK

**CONTROLPOINT SOFTWARE**

**SOURCES AND INPUTS**

- VIDEO SOURCE
- CAMERA INPUT
- COMPUTER

**STREAMING VIDEO SERVER**

**NETWORK INPUTS**

- NETWORK CAMERA
- CPSHARE COMPUTER

**NETWORK INPUTS**



ControlPoint Software



**Jupiter**

the display wall technology company

## CONTROLPOINT™ — COMPLETE AND EFFORTLESS CONTROL OF YOUR JUPITER DISPLAY WALL

ControlPoint is a suite of software applications, software components, device drivers, protocols and an SDK that is bundled with every Fusion and Vizion system. Intelligent user interface design and superb ease-of-use combined with depth of control and extensibility provide Jupiter customers an obsolescence-proof, comprehensive solution for their control room display wall needs.

### CLIENT/SERVER TECHNOLOGY

ControlPoint is based on client-server architecture: the server (ControlPoint server) is installed on a Jupiter Fusion or Vizion display wall processor and interfaces directly with the hardware and operating system, providing high performance access to Jupiter display wall processor functionality. Integral hardware and software design result in stellar performance and consistent usability — regardless of Jupiter processor model, configuration or load.

ControlPoint server implements ControlPoint protocol — an open, efficient, text-based, network communication protocol. ControlPoint protocol is used primarily between the bundled ControlPoint client and ControlPoint server, but can also be used by touch panel devices, control systems and custom applications. ControlPoint protocol communication can be achieved through a TCP/IP socket connection or using serial input with the included ControlPoint connect serial gateway. Conveniently, Jupiter supplies and ActiveX wrapper for ControlPoint protocol, simplifying custom application development.

ControlPoint server maintains complete display wall context; including defined sources and source objects, layouts, keyboard shortcuts, and user login information resulting in a consistent presentation of information to all connected clients.

### CONTROLPOINT CLIENT

ControlPoint client is the primary user interface used to manage a Jupiter display wall processor. Installed on a network connected Windows™-based computer, ControlPoint client connects to the ControlPoint server over a local area network connection. ControlPoint client creates and manages windows displaying connected RGB and video sources, local and network applications, streaming video sources and saves display wall state in layout files for instant or scheduled recall.

### INTUITIVE AND INFORMATIVE INTERFACE

ControlPoint client presents an end user, upon successful login, with a mimic of the display wall complete with lines demarking the boundaries of individual display devices. All windows displayed on the wall, regardless of source, are present on the mimic in accurate proportion and placement. Mimic windows present near real time, scaled-down images of the actual display wall content, a feature unique to ControlPoint. This feature is extremely useful to determine if a window is correctly displaying content, what that content is, and to help users determine which window they are manipulating on large display walls. Mimic window content is configurable in both resolution and refresh rate.

Windows of any type can be placed on the display wall with easy "point and click" operations. RGB input, video input, streaming video, and ControlPoint share windows can be created simply by drawing them on the mimic at the

desired position and size, or by dragging the object from the object list onto the mimic. Local and network application windows can be created and placed by invoking the application directly from the ControlPoint client interface. Convenient display of web sites and web-based applications with custom frames and titling is possible with ControlPoints built-in web viewer object.

### CONTROLPOINT SHARE

ControlPoint share makes it possible to view and fully-interact with any number of computers both

on the Jupiter display wall and the ControlPoint remote client host system using only included software and a network connection. ControlPoint share software is cross-platform, allowing remote control between different types of computers: Windows desktops, Unix-based computers from companies such as Sun, HP and IBM, as well as Linux-based PCs. ControlPoint share windows displayed on a Jupiter display wall processor are fully scalable and can be placed anywhere on the wall. Direct control of the computer that is ControlPoint "shared" is as easy as selecting "Control This Window" from the ControlPoint

client interface; a ControlPoint share window will be displayed on the client's desktop for direct interaction and input.

### APPLICATION SUPPORT

ControlPoint supports executing and managing applications that are installed directly on the display wall processor. Once an application has been defined within ControlPoint as an application object, it can then be saved in layouts to be automatically executed and positioned at a future time, or invoked with a simple double-click of the mouse.

### COMPLETE SOURCE CONTROL

Video, streaming video and RGB inputs that require special handling can be defined as a ControlPoint object easily selected into a ControlPoint window directly from the client properties dialog. When a named input is selected into a window, all of the characteristics of that saved object are applied; including input channel, input type, image properties, source cropping, and RGB timing if applicable. Optionally, selecting a named input can control an external device such as a matrix switch, via either

RS-232 or network connection, to bring the correct source to the appropriate Jupiter Fusion input.

### LAYOUTS

ControlPoint provides the ability to save the state of the display wall into a layout, stored on the display processor, and quickly recall saved layouts directly from the user interface or with user-assignable hot-keys. All windows, including RGB, video, ControlPoint share, and applications objects are saved as part of a layout. Named inputs, custom window properties, and RGB timings are also included in saved layouts. The number of layouts is virtually unlimited.

### SYSTEM MONITORING

Every Jupiter display wall processor has built-in software that monitors the status of critical components and internal environmental conditions. Fan tachometers, power supply voltages, CPU core and chassis ambient temperatures, as well as ECC memory errors are all monitored to ensure they are within normal operational parameters. ControlPoint client displays all monitored values in real time, providing a complete and timely view of the health of the display wall processor. In the event of a system component failing, or falling outside of normal operational parameters, the ControlPoint client displays a visual alarm alerting all connected users of the situation. A log message is also sent to each connected ControlPoint client and placed in the Windows log of the display wall processor. SNMP agents can use ControlPoint messages to provide integration with corporate network management systems. With accurate and timely information regarding required maintenance activity, repair and replacement guesswork is no longer necessary and continuous availability of the display wall is assured.

### CONFIGURABILITY AND EXTENSIBILITY

The ControlPoint protocol and supporting SDK can be used to construct custom applications and implement sophisticated control systems. An RS-232 gateway is provided for serial communication devices. Simple applications using JavaScript and HTML can be generated in minutes, whereas the complete power of a Jupiter display wall processor is available to those who truly want a customized interface and complete control.

### WORLD CLASS SUPPORT

Jupiter Systems is committed to continuous improvement of its software suite of applications, tools and APIs. Jupiter customers participating in extended software support can expect frequent software updates that make their existing purchase more functional, powerful and convenient to use.

### FOR MORE INFORMATION

JUPITER SYSTEMS

31015 HUNTWOOD AVE.

HAYWARD, CA 94544

PHONE: (510) 675-1000

FAX: (510) 675-1001

GO TO: WWW.JUPITER.COM

EMAIL: INFO@JUPITER.COM



*Jupiter and the Jupiter logo are registered trademarks of Jupiter Systems. Vizion, VizionPlus and ControlPoint are trademarks of Jupiter Systems. All other trademarks are property of their respective companies.*

©2006 JUPITER SYSTEMS, INC.  
11/20/06 2.5M

PRINTED IN U.S.A.

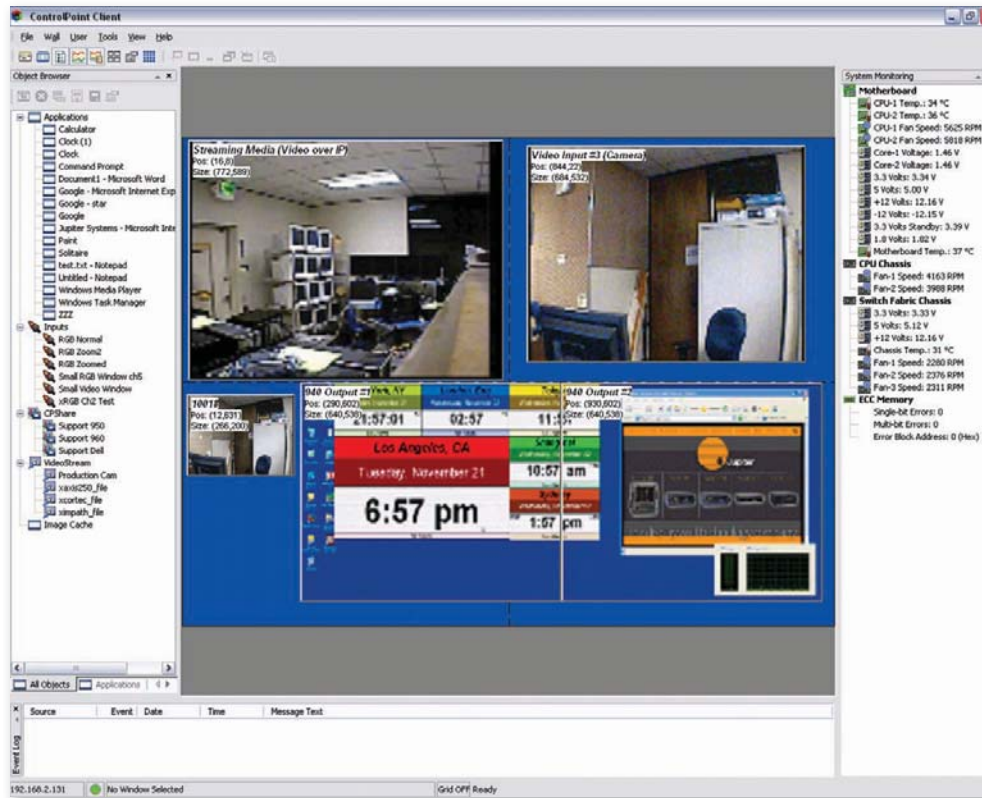

# CONTROLPOINT™ — COMPLETE AND EFFORTLESS CONTROL OF YOUR JUPITER DISPLAY WALL

HP 1910-48G Switch - 48 Ports - Manageable - 44 x RJ-45 - 4  
x Expansion Slots - 10/100/1000Base-T - Rack-mountable



*The HP 1910 switches are advanced smart managed fixed-configuration Gigabit Ethernet lite Layer 3 switches designed for small businesses looking for key enhanced features in an easy-to-administer solution. The series has five models: 16-, 24-, and 48-port 10/100/1000 non-PoE models; and two 24-port 10/100/1000 PoE models. All series switches have four additional true Gigabit Ethernet SFP ports for fiber connectivity. HP 1910 models support rack mounting or desktop operation and use variable-speed fans for quiet operation. The HP 1910 switches operate at full wirespeed, supporting QoS traffic prioritization and security features such as 802.1X network login, access control lists, and denial-of-service prevention. Customizable features include VLANs and link aggregation trunking as well as advanced features such as Layer 3 static routing and Spanning Tree Protocols (STP, RSTP, and MSTP). The HP 1910 switches come with a lifetime warranty covering the unit, fans, and power supplies.*