

Lighting Design Analysis Report

Selmon Expressway Aesthetic Lighting Bid Alternate



Prepared for Tampa Hillsborough Expressway Authority

By:

Kimley-Horn and Associates, Inc.

1777 Main Street, Suite 200
Sarasota, FL 34236
(941) 379-7600
Certificate of Authorization: 00000696

March 2020

Jordan E. Leep, P.E.
FL P.E. No: 76102
Engineer of Record

Contents

List of Figures and Tables.....	2
List of Appendices	2
1.0 Purpose.....	3
2.0 Existing Conditions.....	3
3.0 Roadway Lighting Criteria.....	3
4.0 Roadway Lighting Analysis Methodology	3
5.0 Results and Conclusions	4

List of Figures and Tables

Table 1 Lighting Design .IES File Summary.....	4
--	---

List of Appendices

Appendix A: LUMINAIRE CUT SHEETS

Appendix B: CORRESPONDENCE

Appendix C: COMMENTS & RESPONSES

Appendix D: VOLTAGE DROP CALCULATIONS

Appendix E: PHOTOMETRIC ANALYSIS

1.0 Purpose

This report summarizes the results of the aesthetic lighting design analysis conducted for the Selmon Expressway Reverse Elevated Lanes in Tampa, FL. The lighting improvements stretch the entire length of the elevated lanes. The scope of design services includes a lighting system that is aesthetically pleasing, visually consistent, operationally efficient, and cost effective to maintain. The lighting system is to utilize an outdoor rated LED system that will stand up to harsh outdoor environments, will prevent vandalism, will offer superior light output and will be programmable from the THEA Traffic Management Center (TMC). The objective of the analysis is to create a visually pleasing driving experience for the driver and a landmark recognized across the city of Tampa.

2.0 Existing Conditions

This project is located in Tampa, FL along the Selmon Expressway reverse elevated lanes from Twiggs St. on the west end to east of the Bypass Canal and the overhead tolling gantry at the east end, a distance of approximately 6 miles.

The existing lighting system within the project limits is owned and maintained by THEA. Existing luminaires attached to structural arms provide downlighting on the piers, straddle bents, abutments, and retaining walls. These luminaires are connected to existing DMX cables that originate at junction boxes holding proposed DMX for future luminaires. Conduit through the deck of the expressway connects these junction boxes into existing cabinets also within the deck.

3.0 Roadway Lighting Criteria

There is no governing criteria for aesthetic lighting. The attached photometric analysis shows that the increased illuminance from the new fixtures onto the Selmon Expressway lower lanes is minimal. All structural arms are designed for a wind speed of 150 mph.

4.0 Roadway Lighting Analysis Methodology

When picking an LED fixture, flexibility and reliability had to be prioritized. Fully programmable color changing LED luminaires allow for simple installation and low operational costs. Their steel frame makes them reliable and resistant to vandalism and their built-in drivers and onboard programming capability make them an extremely flexible lighting solution. We chose to go with high powered wash luminaires to project more light and cut down on the amount of fixtures for the overall project. This not only reduces the expense for the fixtures, but it also gives a much cleaner look to the system with fewer luminaires. This also reduces the number and size of conductors throughout the project, another cost saving measure.

When determining the luminaire locations, the primary concern was to avoid glare and light pollution for the roadway traffic on the lower lanes. Secondly, the placement of the luminaires also needed to prohibit vandalism. Lastly, we focused on placing the luminaires in a way that would minimize traffic impacts both during construction and during maintenance work.

The Acclaim Dyna Drum HO QW Color and Dyna Drum SO luminaires were selected for this project because they are extremely powerful fixtures that also offer a variety of lens options. The HO and SO are extremely similar in appearance, giving a uniform appearance throughout the entire project. The base

model has a beam spread of 10°, which will be used for the long throw along the center underside of the elevated lanes. The 10° x 60° lens option, which flattens the beam out dramatically, will be used as up lighting for the underside wings of the elevated. The 60° lens option will be used to light the cross members of the straddle bents and backside of the abutments. The SO has the same features and the same lens options as the HO; it's just a more economical solution where less lumens are needed. The intention of the bid alternate is to supplement the luminaires in the base bid with the remaining luminaire spots on the existing structural arms to illuminate the underdeck of the bridge.

The Dyna Drum's quad color chip provides superior color mixing and saturation over single source LED fixtures. RGBW (red, green, blue & white) color mixing gives us the option to create pure color palettes including a pure white light. The quad chips also eliminate any color shadows that regular RGB light fixtures produce on a surface close to the light source. Both fixtures will be powered on 240V circuits which falls within their operating range of 100 – 277 VAC. The IP rating for both Dyna Drums is IP66 in wet locations. The location of the fixtures close to the piers should minimize exposure to water. The limited warranty for these fixtures is 5 years.

Table 1 Lighting Design .IES File Summary

Manufacturer	Fixture Name	Lens	Weight	Wattage	Associated .ies File
Acclaim	Dyna Drum HO QW Color	10°x60°	30 lbs	250W	Dyna Drum HO QW 10x60°
Acclaim	Dyna Drum SO	10°	26.4 lbs	147W	Dyna Drum SO QW 10°
Acclaim	Dyna Drum SO	60°	26.4 lbs	147W	Dyna Drum SO QW 60°

All the lighting fixtures are DMX+RDM. DMX is the industry standard for controlling all intelligent light fixtures. With RDM (Remote Device Management) this will give us the option to access the fixtures from the THEA TMC or remotely in the field without having to be next to the fixture. This will enable us to easily communicate with the fixtures and simplify trouble shooting. This is an extremely useful feature for an installation of this size and complexity.

With the design we have proposed, we will deliver a very flexible lighting system. The system has the capability to be preprogrammed with designs that will be stored in the Pharos controller. Each day can have its own individual show that can be triggered to commence by the atomic clock at sunset and conclude at sunrise or can be given hard times to start and finish. All effects are customizable by anyone who has access at THEA's TMC. The controller will tie in to existing fiber at THEA's TMC and send the signals along this backbone. Throughout the project we will peel off of the fiber optic runs to ITS cabinets where DMX will be utilized to control every fixture.

The lighting design and analysis was conducted using AGi32 v19.2 lighting analysis software.

5.0 Results and Conclusions

After completing photometric analysis for the corridor, it has been determined that the Dyna Drum fixture will be aesthetically pleasing, visually consistent, operationally efficient, and cost effective to maintain. Full photometric rendering for the proposed lighting system is included in Appendix E.

APPENDIX A: LUMINAIRE CUT SHEETS

DYNA DRUM HO COLOR™

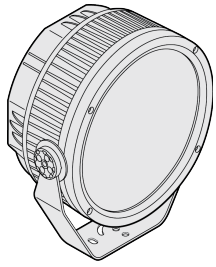

Client:

Project:

Type:



Order Code:

Quantity:



Dyna Drum HO Color is a high output, outdoor rated, quad color LED floodlight. It features an internal 100-277VAC power supply, onboard DMX+RDM driver, and each unit carries Acclaim's Aria wireless DMX technology inside. The quad color chip provides superior color mixing and saturation over single source LED fixtures. It comes with a narrow 10° beam standard, with optional quick-change spread lenses for wider applications. It is ideal for facade lighting applications and as an area floodlight.

SPECIFICATIONS

Colors	QW: RGBW (W=6000K), QS: RGBW (W=3000K)
Beam Angles	10° standard, 20°, 40°, 60°, 10° x 60° spread lens options
Photometrics	7660 lumens, 161,203 cd, see page 4 for details
Effective Projected Area	1.75 ft ²
Control	DMX+RDM, Manual color setting in menu, photocell included, Aria wireless direct connect
Max Fixtures in Series	32 via DMX, power local to each fixture
Power Consumption	250W
Operating Voltage	100-277VAC, 50/60 Hz
Lumen Maintenance	L70 @ 150,000 hours (25° C)
Mounting	Surface mount bracket included, optional tenon mount and pipe clamp available
Finish	Gray standard (RAL 7047), black, white, and custom colors optional
Material	Die cast aluminum, glass top lens, optional marine coating available
Ambient Operating Temperature	-40° F to 125° F (-40° C to 51° C)
IP Rating	IP66, wet location
IK Rating	IK07, protection against 2 joule impact
Fixture Connectors	Attached 5' (1.5m) IP66 hybrid cable, AC power +DMX/RDM
Warranty	5 Years, limited
Weight	30 lbs. (13.6 kg)
Dimensions	L: 14.8" x W: 15.4" x D: 8.2" (378mm x 393mm x 209mm)
Certifications	 

ORDER CODES

* indicates special order

DDJ - 2 # 1 - A C # N

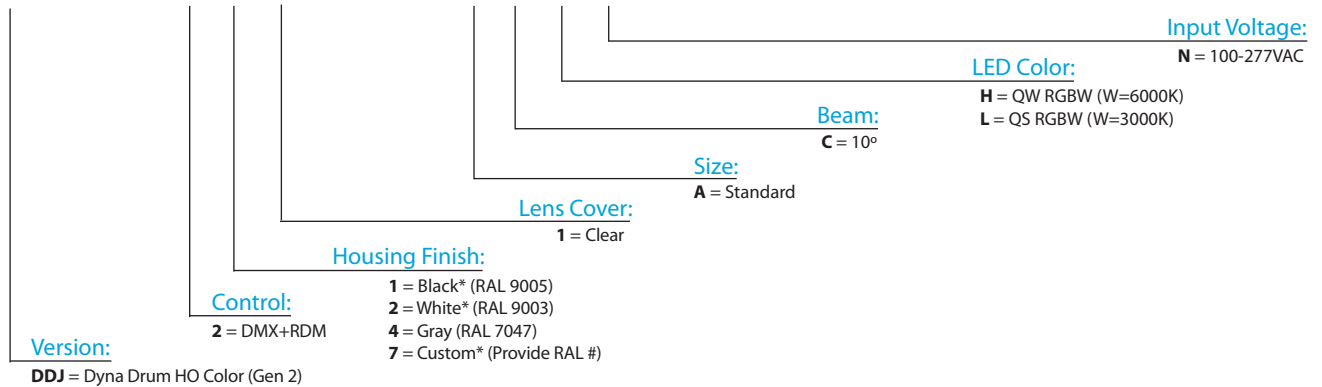

RELATED COMPONENTS

Optional Beam Accessories



DDHSL20
20° Spread lens for Dyna Drum HO Color

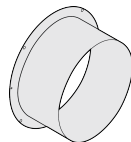

DDH2FSG
Full snoot for Dyna Drum HO Color, Gray

DDHSL40
40° Spread lens for Dyna Drum HO Color

DDHSL60
60° Spread lens for Dyna Drum HO Color

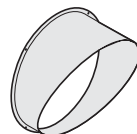

DDHSL1060
10° x 60° Spread lens for Dyna Drum HO Color

DDH2HSG
Half snoot for Dyna Drum HO Color, Gray

RELATED COMPONENTS

Optional Mounting Accessories

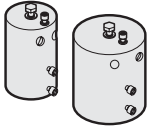

TM2
2" pipe, schedule 40 tenon mount
(2.51", 56mm inner dia.)

TM4
3.5" pipe, schedule 40 tenon mount
(4.13", 105mm inner dia.)



PC2
2" pipe, schedule 40 pipe clamp
mounts 1 or 2 fixtures

PC4
4" pipe, schedule 40 pipe clamp
mounts 1 or 2 fixtures

DIMENSIONS

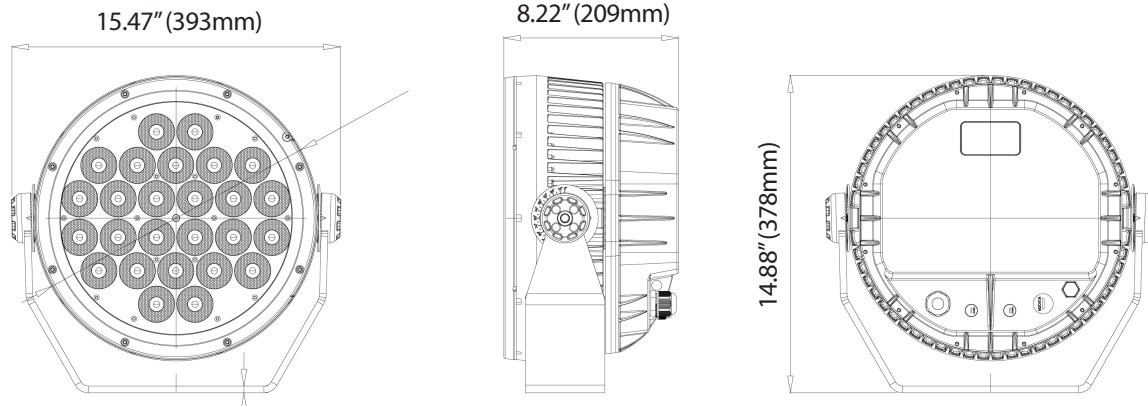

WIRING

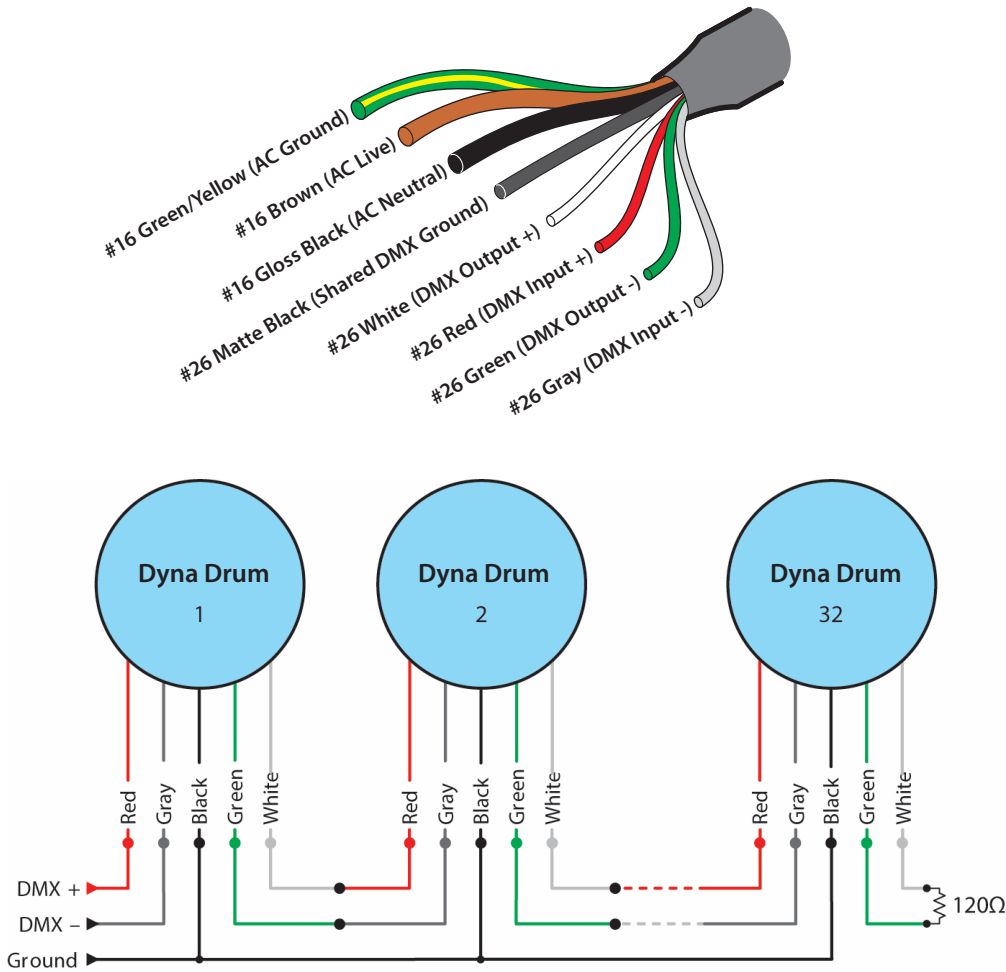

PHOTOMETRICS

Color Temp / Beam	Lumens	Center Candela	Efficacy (l/pw)	CRI (Ra)	CRI (r9)
QW RGBW, 10°	7660	161,203	31	-	-
QS RGBW, 10°	7741	183,376	31	-	-

Dyna Drum SO™

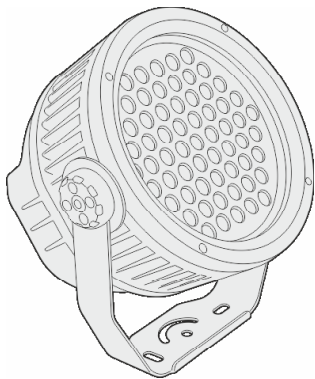

Client:

Project:

Type:



Order Code:

Quantity:



The **Dyna Drum SO** is a high output, outdoor rated, LED flood fixture. It features an adjustable yoke, on-board digital display, a 100-277VAC internal power supply, and a built in receiver for the Aria wireless DMX system. It is ideal for facade lighting applications, and as an area flood light.

Specifications

Color Temperature	RGBW, RGBA, 2700K, 3000K, 3500K, 4000K, 5500K, DW (2400K-5500K)
Beam Angle	6° (standard), 20°, 40°, 60°, 10° x 60° spread lens options
Total Lumens	7,769 at 5500K, 6° / 4656 at RGBW, 6°
Center Beam Candela	344,366 at 5500K, 6° / 148,001 at RGBW, 6°
Control	DMX-512, 4 channels (color), 3 Channels (DW), or 1 Channel (white)
Max Fixtures in Series	32, via DMX-512
Effective Projected Area	Front: 0.72, Side 0.74 (includes drag coefficient)
Power Consumption	157W at steady state
Operating Voltage	100-277VAC, 50/60Hz
Lumen Maintenance	L70 @ 120,000 Hours (25° C)
Finish	Gray (Standard), White or Black (Optional)
Housing Material	Die Cast Aluminum, Optional Marine Environment Coating Available
Operating Temperature	-40° F to 122° F (-40° C to 50° C)
IP Rating	IP66, Wet Location
Fixture Connectors	Attached 5' (1.5m) IP 66 AC Power + Signal Cable
Warranty	5 Year Limited Warranty
Weight	26.4 lbs (12 kg)
Dimensions	9.13" ø x W 8.39" x H 14.13" (232mm ø x W 213mm x H 359mm)
Certifications	  

Order Codes

* Indicates Special Order

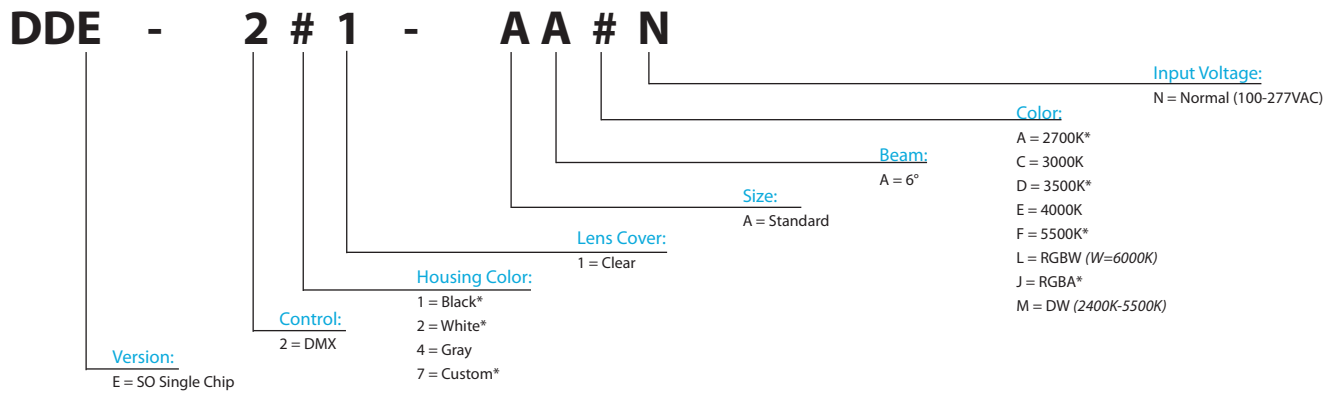

Related Components

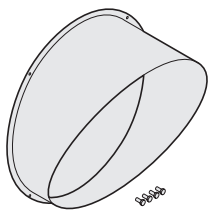

Half Snoot

Gray: DDSOHSG
Black: DDSOHSB
White: DDSOHSW

Includes four M4 mounting screws

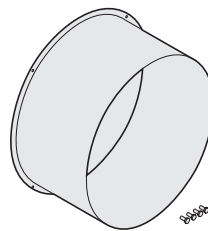

Full Snoot

Gray: DDSOFSG
Black: DDSOFSB
White: DDSOFSW

Includes four M4 mounting screws

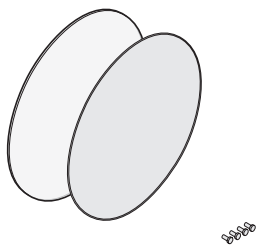

Spread Lens Kits

20° Beam: DDSSL20
40° Beam: DDSSL40
60° Beam: DDSSL60
10° x 60° Beam: DDSSL1060

Includes four M4 mounting screws

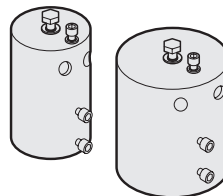

Tenon Mount

For 2" pipe: TM2
For 4" pipe: TM4

Dimensions

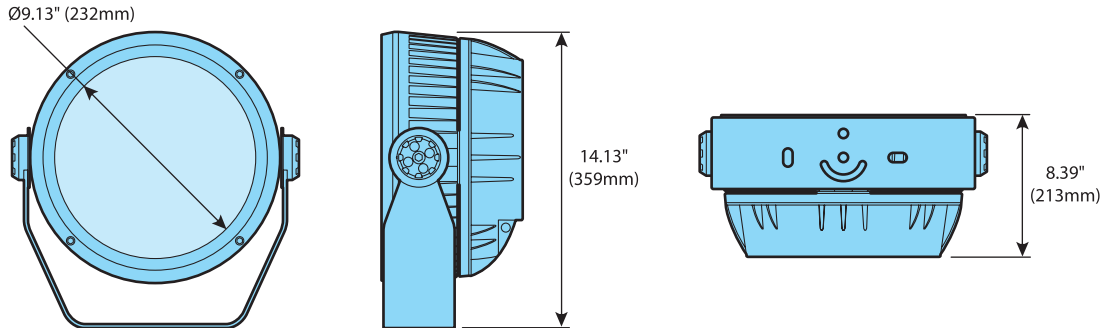

Wiring

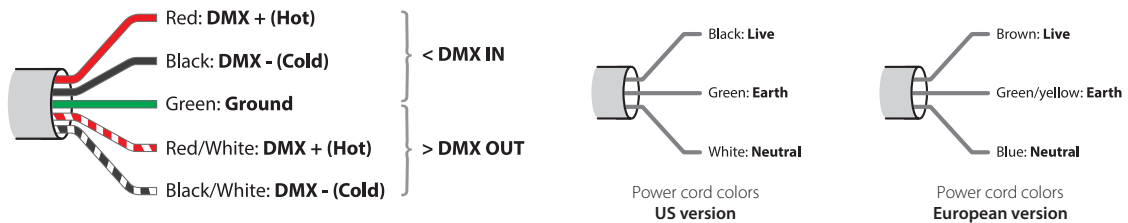

Photometrics

For IES & Revit files, please visit acclaimlighting.com

5500K, 6°

Zonal Lumen Summary

Zone	Lumens	%
0-60	7634	98.3
60-90	131.8	1.7
90-180	2.8	0.0
Total	7769	100

Polar Candela Distribution

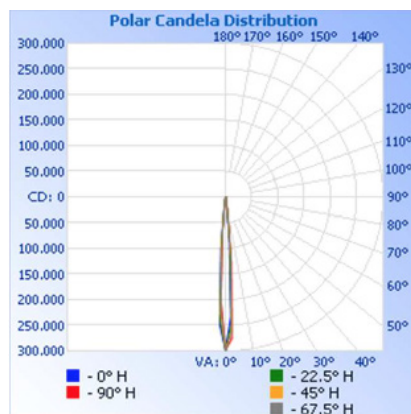

Isofootcandle Plot

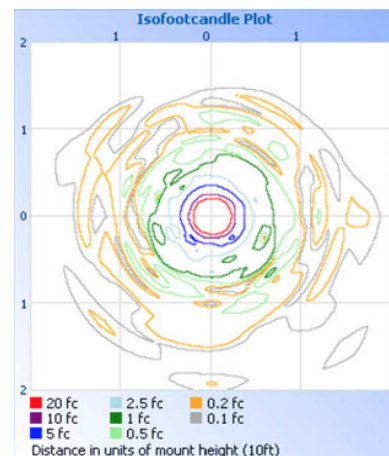

Dyna Drum SO™

Photometrics (Con't)

RGBW, 6°

Zonal Lumen Summary

Zone	Lumens	%
0-60	4556	97.9
60-90	96.3	2.1
90-180	3.7	0.1
Total	4656	100

Polar Candela Distribution

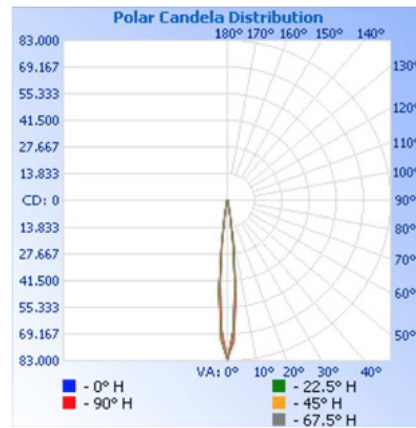

Isofootcandle Plot

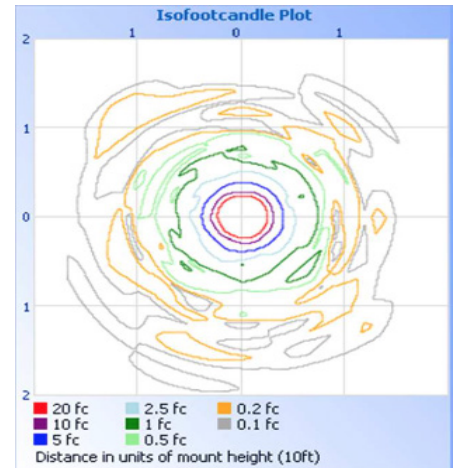

OUTDOOR LINK SYSTEM™

ACCLAIM LIGHTING

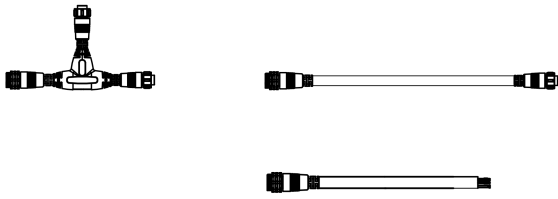

Client:

Project:



Type:

Order Code:

Quantity:

The **Outdoor Link System** is an IP67 rated solution for linking some Acclaim fixtures in series. It provides a quick and easy way to inter-connect fixtures while eliminating excess hardware for a project.

SPECIFICATIONS

Connection options	"T" Junction (OLS T), Link Cable (OLS L), Feed Cable (OLS F)
Lengths	See page 2 for options
AC Conductors	3 x 14AWG
DMX Conductors	4 x 20AWG + shield
Maximum Input Voltage	305VAC
Maximum Total Line Amperage	15A
Maximum Total Line Wattage	120VAC: 1.8 kW, 277VAC: 4.155 kW
Surge Voltage	1000V
Flame Resistance	UL94-V0
Finish	Gray cable, black connectors
IP Rating	IP67, Wet Location
Ambient Operating Temperature	-40° F to 176° F (-40° C to 80° C)
Connectors	7 pin push lock connectors with IP67 rubber seal
Warranty	5 Years Limited
Weight	OLS T: 0.3 lbs (136 g), OLS L & F: Various, length dependant
Dimensions	Connector: ø 1.493" (37.9mm) x L: 3" (78.4mm) Cable: ø 0.676" (17.17mm) x spec'd length
Certifications	 

ORDER CODES

OLS #

Length (not required for OLST)

- 1 = 1' (0.3M)
- 5 = 5' (1.52M)
- 10 = 10' (3.04M)
- 25 = 25' (7.62M)
- 50 = 50' (15.24M)

Connection Type:

- F = Feed Cable
- L = Link Cable
- T = "T" Connector

DIMENSIONS

Input Connector (Male)

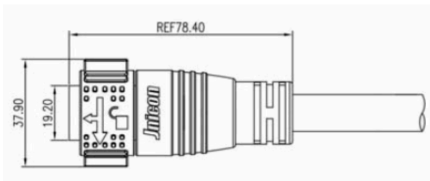

Output Connector (Female)

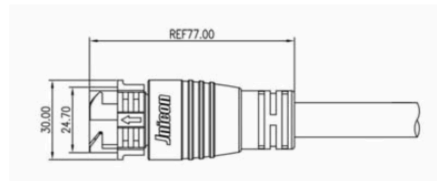

NEC compatible AWM hybrid cable

600VAC, 80° C

Separate, shielded PVC barrier inside the cable
Wiring barrier inside AJBOX1

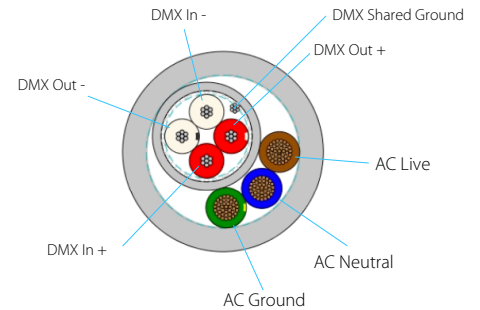

LAYOUT

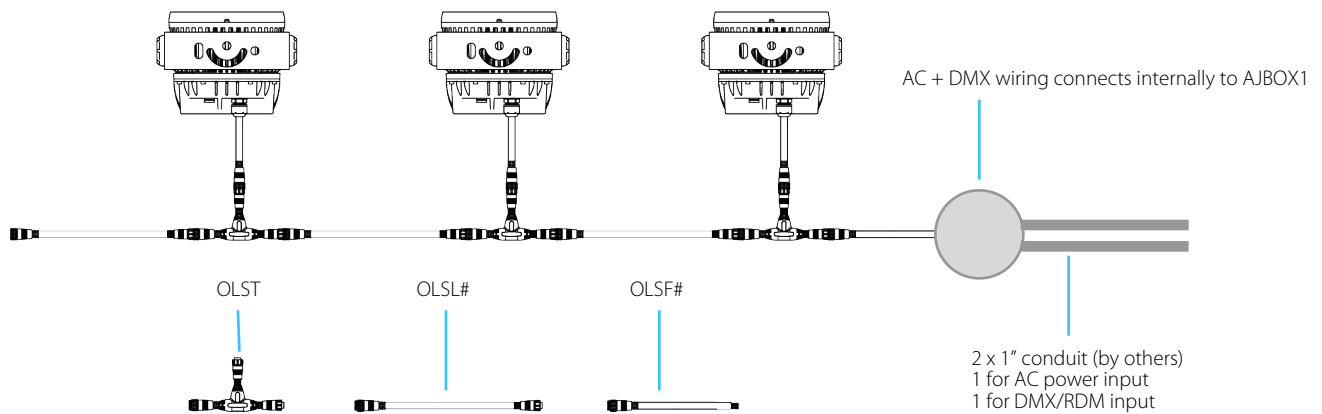

APPENDIX B: CORRESPONDENCE

THEA Lighting Project Meeting

(02-07-2020)

Discussions items included:

1. Provide calculations via email to Julian Gutierrez @ jwgutierrez@HNTB.com for tension force to be applied at top bar and STAAD model of frame for his review and comments.
2. Holes at the bottom of the existing slab can be used for conduits.
3. Use Galvanized Steel.
4. Use undercut anchors included in the Approved Products List (APL) instead of epoxy anchors.
5. Provide four (4) bolt connections at the abutments.
6. Provide notes detailing torque requirements, etc.
7. Provide detail for holes for conduits at moment connections.
8. Vertical clearance to be verified at Straddle Bents in FIGG Plans. Minimum vertical clearance is 16'-0".
9. Verify post-tensioning is not present in the lighting to be installed inside the box.
10. Provide a smooth finish note at the end of the tubing.

2020-01-16 THEA Aesthetic Lighting Concept Review

Thursday, January 9, 2020 10:44 AM

The current aesthetic lighting structural connection at the typical pier locations is shown on plan sheet no. 49. It consists of two mounting brackets with anchor bolts into the pier column per vertical post. This structural connection is mirrored so that is located on both the upstation and downstation face of the pier column. This concept is shown in the three figures below.

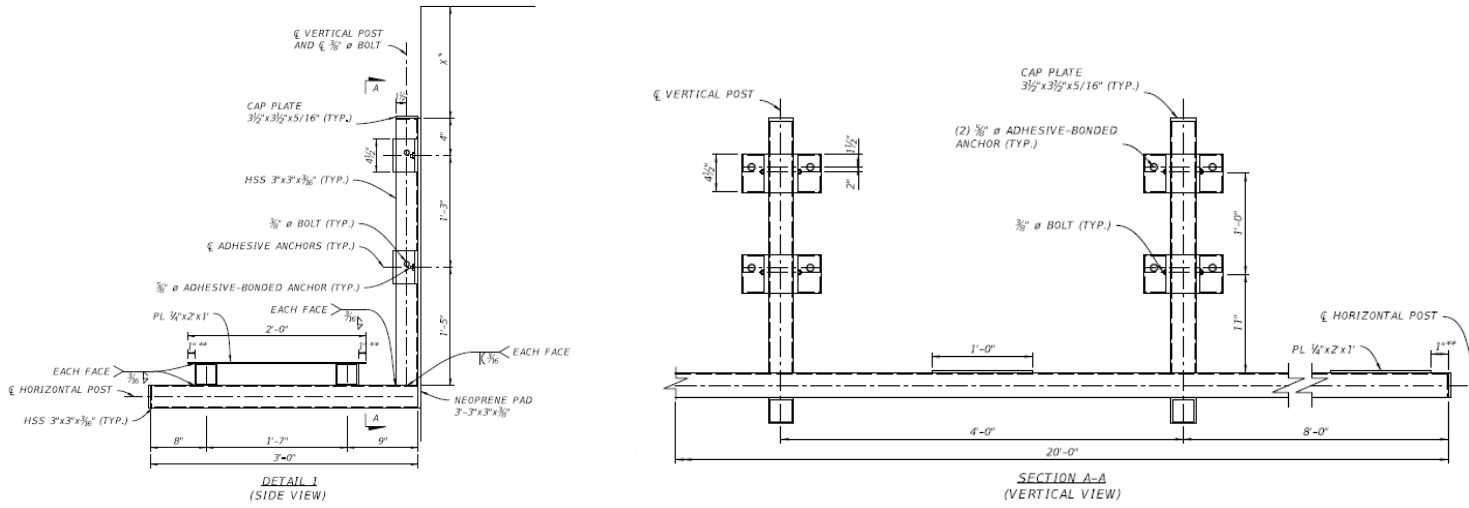

THEA had requested Kimley-Horn to investigate the feasibility of a concept where both vertical posts on one side of the pier column extend up and over the top of the pier column to connect to the corresponding vertical post on the other side of the pier column. The intent was to eliminate the need for the mounting brackets and anchor bolts into the pier column.

Lateral/Uplifting Wind Loadings on Support Frame Require Mechanical Connection to Pier Column

The bottom frame that supports the aesthetic lighting luminaires is wide and extends past the pier column. Due to its geometry, it will be subjected to lateral and uplifting wind loads that will produce a torque or wracking of the entire aesthetic lighting support frame. If the vertical posts that extend up and over the top of the pier are not mechanically fastened to the pier column (e.g. anchor bolts into the pier column), the entire support frame will be subject to movement during wind events. In order to prevent this movement, mechanical fasteners/anchor bolts would still be required to fix the support frame to the pier column. Another option would be to implement a thread bar system that would connect the support frames on either side of the pier. The thread bar system would run external to and alongside of the pier column to connect the support frames and providing a clamping force. Because these bars

would be external, this would not be an aesthetically pleasing solution.

Minimum Clearance on Top of Pier Column to Install Anchor Bolts

The minimum neoprene bearing pad height is 4 7/16" and the minimum heights for both the bearing seat (concrete pedestal under the bearing) and bearing plinth (concrete above the bearing/under the superstructure segment) are each 2". That means that the minimum height from the top of the pier column to the bottom of the superstructure segment is 8 7/16". This leaves very little room to access the vertical strut extensions on top of the pier column to install anchor bolts. Any anchor bolts would need to be installed along the side of the pier column for access purposes.

The vertical posts that extend up and over the top of the pier column must also take into consideration the drain pipe and bearing replacement schemes for future bearing replacement. This further restricts the available space on top of the pier column for the vertical posts that extend up and over the top of the pier column.

Means and Methods to Protect the Existing Structure

Based on studying the feasibility of extending the vertical posts up and over the top of the pier column, Kimley-Horn recommends to move forward with the existing concepts where the vertical posts are mechanically fastened to the side of the pier column with anchor bolts. Rebar locating methods using nondestructive techniques are readily available (e.g. ground penetrating radar "GPR" methods) to locate the reinforcing steel and locate where the anchor bolts need to be placed. Locations and dimensions are provided in the aesthetic lighting support frame plans for the contractor to start with their rebar locating methods. The aesthetic lighting support frame will be detailed so that it can accommodate any deviation to the transverse distance between the vertical posts (currently 4'-0") and the brackets supporting the vertical posts (dimensioned from the top of the pier column).

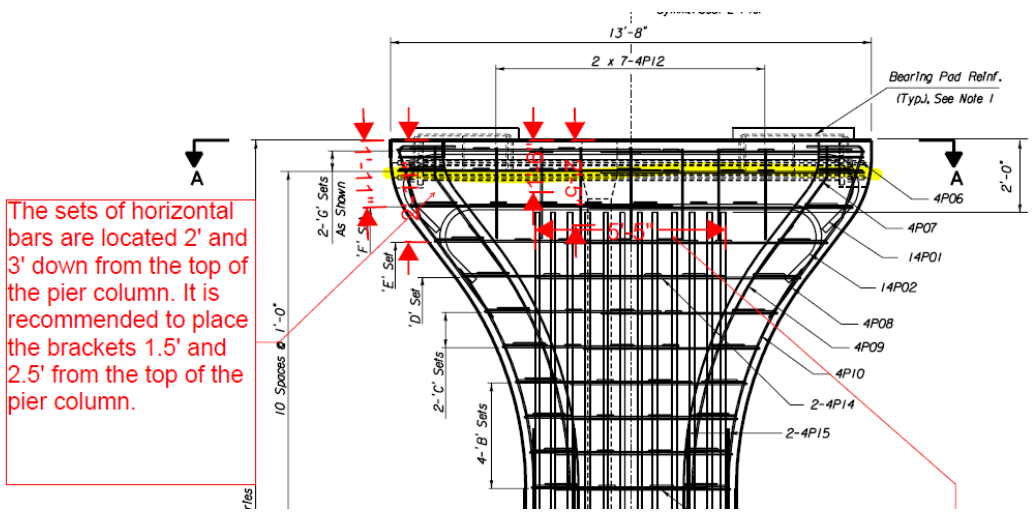

Rehm, Jacob

From: Judith Villegas <judith.villegas@tampa-xway.com>
Sent: Thursday, January 16, 2020 10:24 AM
To: Rehm, Jacob
Cc: Leep, Jordan
Subject: RE: Aesthetic Lighting Abutments

Categories: External

Jacob,

Thanks for including photos, that is always helpful. We agree that those abutments don't need down lighting with the piers being so close to them. Thanks for catching this.

Judith

From: Rehm, Jacob <Jacob.Rehm@kimley-horn.com>
Sent: Wednesday, January 15, 2020 5:17 PM
To: Judith Villegas <judith.villegas@tampa-xway.com>
Cc: Leep, Jordan <Jordan.LEEP@kimley-horn.com>
Subject: Aesthetic Lighting Abutments

Hey Judith,

After performing a constructability site review on Monday with a fellow employee with vast construction experience, it was determined that the majority of abutments will not require down lighting as called for in the base bid. These locations are at abutment 173, 124, and 123. In particular, abutment 173 only seen from N 12th Street is tucked behind a warehouse, next to vacant lots, and is hardly visible from other overpasses, truly not needing any luminaires. Pier 172 is close enough to it that the light from those luminaires would still give it some attention. I wanted to run this by you since it strays from the standard approach, but after running the material costs it will save THEA \$40k. Please see google images for a quick glance at what I'm referring to and let me know how you feel about this change.

Thank you,

Jacob N. Rehm | EI
Kimley-Horn | 1777 Main St Ste 200, Sarasota, FL 34236
Direct: 941 379 7628 | Mobile: 717 645 9362

Rehm, Jacob

From: CEREPS <CEREPS@tecoenergy.com>
Sent: Friday, November 22, 2019 9:27 AM
To: CJKirby@tecoenergy.com; Rehm, Jacob
Cc: Leep, Jordan
Subject: RE: LOAD CENTERS [<AD84777>]

Categories: External

Good morning,

Jacob Rehm,

This is Ralph Torres in the New Construction department. Do you have the address for these Load Center. I would like to have this job assigned to one of our representative in our department.

Thank you,

Ralph Torres

New Construction.

Original Message:

From: CJKirby@tecoenergy.com
Sent: Friday, November 22, 2019 9:11:06 AM
To: "Rehm, Jacob" <Jacob.Rehm@kimley-horn.com>
Cc: "Leep, Jordan" <Jordan.Leep@kimley-horn.com>; CEREPS CEREPS <CEREPS@tecoenergy.com>
Subject: RE: LOAD CENTERS

Good morning Jacob,

I am no longer in the New Construction department that handles requests such as this. I have copied the Customer Engineering Representative mailbox for assignment to your new representative.

Best Regards,

Lena Kirby

Lighting Field Engineering Technician

Tampa Electric

(O) 813-635-1467

(C) 813-447-1509

cjkirby@tecoenergy.com

<https://www.tampaelectric.com/residential/start-service/outdoorlighting>



From: Rehm, Jacob <Jacob.Rehm@kimley-horn.com>
Sent: Friday, November 22, 2019 8:42 AM
To: Kirby, Lena J. <CJKirby@tecoenergy.com>
Cc: Leep, Jordan <Jordan.Leep@kimley-horn.com>
Subject: RE: LOAD CENTERS

Citrix Attachments Expires May 20, 2020

THEA Aesthetic Lighting_Load Centers.pdf	83.9 MB
THEA -Breaker Summary.pdf	51.7 KB
Voltage Drops Calcs.pdf	822.1 KB

[Download Attachments](#)

Jacob Rehm uses Citrix Files to share documents securely.

Lena,

I am reaching out to let you know that THEA has made this project active again, so we are approaching a 90% submittal in early December. I have attached updated plan sheets that show the locations of our proposed load centers; the total count remains at eleven as before and the locations should be the same as the .dgn Everett sent. Updated voltage drop calculations and breaker loads are also attached. Please see Everett's previous email for the service request at each (single phase, 240/480V). Hopefully we can salvage the applications from last year. Lastly, I will be your future point of contact for the remainder of the project, so please feel free to reach out for whatever you need.

I appreciate your help,

Jacob N. Rehm | EI
Kimley-Horn | 1777 Main St Ste 200, Sarasota, FL 34236
Direct: 941 379 7628 | Mobile: 717 645 9362

From: Loving, Everett
Sent: Monday, July 30, 2018 4:17 PM
To: Kirby, Lena J. <CJKirby@tecoenergy.com>
Cc: Leep, Jordan <Jordan.Leep@kimley-horn.com>
Subject: RE: LOAD CENTERS

Hey Lena,

We are requesting single phase service, with a triplex distribution. The Voltage should be 240V/480V with 2 hot wires of 240V and one neutral wire. This is standard for roadway lighting. As for the electrician, we are just the consultants doing the lighting design. A contractor has not been selected yet to do the work.

Let me know if you have any more questions.

Thanks,

Everett Loving, E.I.

Kimley-Horn | 1777 Main St, Sarasota, FL 34236

Direct: 941 379 7603 | Mobile: 423 283 7366

Connect with us: [Twitter](#) | [LinkedIn](#) | [Facebook](#) | [Instagram](#)

Celebrating 11 years as one of FORTUNE's 100 Best Companies to Work For

From: Kirby, Lena J. [<mailto:CJKirby@tecoenergy.com>]

Sent: Monday, July 23, 2018 9:22 AM

To: Loving, Everett <Everett.Loving@kimley-horn.com>

Cc: Leep, Jordan <Jordan.Leep@kimley-horn.com>

Subject: RE: LOAD CENTERS

Good morning,

I have created your work requests for the 11 load centers; however, I have a few questions.

Can you please confirm that you are requesting single phase service? Also, your voltage, should that be 277/480 volts? Can you please provide your electricians contact information?

Thank you,

Lena Kirby

One Source/New Construction

813-275-3525

813-635-1500 Ext. 28416

cjkirby@tecoenergy.com

[Link to Tampa Electric's Construction web page](#)



"Our Code of Conduct Principles"

Safety, Health & The Environment | Customers | Integrity | Respect and Collaboration | Excellence

From: Loving, Everett [<mailto:Everett.Loving@kimley-horn.com>]

Sent: Thursday, July 05, 2018 1:27 PM

To: Kirby, Lena J.

Cc: Leep, Jordan
Subject: RE: LOAD CENTERS

CAUTION - External Email

******* Don't be quick to click! We're counting on you! This email is from an external sender! Don't click links or open attachments from unknown sources. Forward suspicious emails as an attachment to phishing@tecoenergy.com for analysis by our cyber security team. *******

Lena,

Please see the attached folder for the following:

- 11 Load Center Applications
- 11 sets of Voltage Drop Calculations
- FDOT Service Point Standard Detail
- Lighting Design File in .dgn format (.dwg can be provided if necessary)
- Load Center Summary Document

Please let me know if you need anything else.

Thanks,

Everett Loving, E.I.

Kimley-Horn | 1777 Main St, Sarasota, FL 34236

Direct: 941 379 7603 | Mobile: 423 283 7366

Connect with us: [Twitter](#) | [LinkedIn](#) | [Facebook](#) | [Instagram](#)

Celebrating 11 years as one of FORTUNE's 100 Best Companies to Work For

From: Kirby, Lena J. [<mailto:CJKirby@tecoenergy.com>]

Sent: Thursday, June 21, 2018 11:15 AM

To: Loving, Everett <Everett.Loving@kimley-horn.com>

Subject: LOAD CENTERS

Hi Everett,

Attached is my commercial application for you to complete for each of the 11 new load centers.

Disregard the plans section on the 1st page, since these are only load centers, I will only need the electrical riser diagram, panel schedule and load calculations.

Feel free to contact me with any questions you may have.

Thanks,

Lena Kirby

One Source/New Construction

813-275-3525

813-635-1500 Ext. 28416

cjkirby@tecoenergy.com

[Link to Tampa Electric's Construction web page](#)



"Our Code of Conduct Principles"

Safety, Health & The Environment | Customers | Integrity | Respect and Collaboration | Excellence

NOTICE: This email is intended only for the individual(s) to whom it is addressed and may contain confidential information. If you have received this email by mistake, please notify the sender immediately, delete this email from your system and do not copy or disclose it to anyone else. Although we take precautions to protect against viruses, we advise you to take your own precautions to protect against viruses as we accept no liability for any which remain.

Rehm, Jacob

From: Leep, Jordan
Sent: Wednesday, October 30, 2019 10:34 AM
To: Rehm, Jacob
Subject: FW: project coordination DMS replacement project
Attachments: Downtown Package.pdf; 34th St DMS Package.pdf; 301 Site Plan2.pdf; 78th Street Site Plan2.pdf; Brandon Site Plan2.pdf

FYI – we will need to go through these and make sure they are not impacting our improvements.

From: Judith Villegas [mailto:judith.villegas@tampa-xway.com]
Sent: Wednesday, October 30, 2019 10:25 AM
To: Leep, Jordan <Jordan.Lee@kimley-horn.com>; Terry Opdyke <topdyke@hntb.com>
Subject: RE: project coordination DMS replacement project

Jordan,

Attached are the plans for the DMS project. The last 4 signs should be installed by the end of January 2020. Let us know if you need anything else.

Thanks,
Judith

From: Leep, Jordan <Jordan.Lee@kimley-horn.com>
Sent: Wednesday, October 30, 2019 10:03 AM
To: Judith Villegas <judith.villegas@tampa-xway.com>; Terry Opdyke <topdyke@hntb.com>
Subject: project coordination DMS replacement project

Judith,

Can you send us the latest plans for the DMS replacement project? We want to make sure we will not have any integration issues or overlap with that project.

Thanks,

Jordan Leep P.E., PMP
Kimley-Horn | 1777 Main Street, Suite 200, Sarasota FL 34236
Direct: 941 379 7647 | Mobile: 906 869 2214

Rehm, Jacob

From: Leep, Jordan
Sent: Friday, November 1, 2019 11:01 AM
To: Rehm, Jacob
Subject: FW: THEA Selmon Expressway Lighting project

Can you confirm the current total number of luminaires?

From: Sara Calhoun [mailto:scalhoun@vibengineering.com]
Sent: Friday, November 1, 2019 10:21 AM
To: Leep, Jordan <Jordan.Lee@kimley-horn.com>
Cc: Todd Patton <tpatton@vibengineering.com>
Subject: FW: THEA Selmon Expressway Lighting project

FYI, this was the previous conversation with Metric.

From: Todd Patton <tpatton@vibengineering.com>
Sent: Friday, November 1, 2019 8:58 AM
To: Sara Calhoun <scalhoun@vibengineering.com>
Cc: Vivek Koneru <vkoneru@vibengineering.com>
Subject: FW: THEA Selmon Expressway Lighting project

Sara, is ok to release the pages from the plans that are relevant to Scott's questions?

Thanks,
Todd

From: Scott Agans <scott.agans@metriceng.com>
Sent: Friday, November 01, 2019 8:52 AM
To: Todd Patton <tpatton@vibengineering.com>
Cc: Rolando Ramirez <Rolando.Ramirez@metriceng.com>; Eric Wyllins <eric.wyllins@metriceng.com>
Subject: RE: THEA Selmon Expressway Lighting project

Todd,

THEA has responded to Metric and approved us to work on the fiber verification for you. We are now waiting on a Task Work Order to be executed before we can start. Can you send us any information or initial plan sets regarding this system? Will this system need to be integrated into the existing ITS network or will this be a stand alone system? If so, I will need to assign you an IP block for the units and need to know how many to assign.

Thank you,

SCOTT AGANS
Associate Technology Manager



525 Technology Park, Suite 153

Lake Mary, FL 32746
Office: (407) 644-1898
Cell: (407) 432-2732
Fax: (407) 644-2376
scott.agans@metriceng.com

From: Todd Patton <tpatton@vibengineering.com>
Sent: Wednesday, October 30, 2019 4:18 PM
To: Scott Agans <scott.agans@metriceng.com>
Cc: Rolando Ramirez <Rolando.Ramirez@metriceng.com>
Subject: RE: THEA Selmon Expressway Lighting project

Thank you Scott. If there is anything I can do to help in the meantime, please reach out to me.

Todd

Todd Patton
Traffic / ITS Systems Analyst

VIBE
A Certified DBE/SBE/WBE/MBE Company

700 Central Avenue
Suite 302
St. Petersburg, FL 33701
727.317.4967 office
813.446.8392 cell

www.VIBEngineering.com | tpatton@VIBEngineering.com



Rehm, Jacob

From: Tracey Dear <tracey@dearproductions.com>
Sent: Friday, November 1, 2019 1:42 PM
To: Leep, Jordan
Cc: Rehm, Jacob
Subject: Re: DMX Wiring
Attachments: Outdoor Link System 2.0.0.pdf

Categories: External

Here is the T link spec sheet.

I have a few questions but won't get answers for a couple more hours when they get out of conference meeting.

Tracey Dear | tracey@dearproductions.com

Dear Productions Inc.
329 North Maple Avenue | Oak Park, IL 60302
Phone: (708) 445-0432 | Cell: (773) 294-1540
<http://www.dearproductions.com>



On Nov 1, 2019, at 10:47 AM, Tracey Dear <tracey@dearproductions.com> wrote:

Hey Jordan,

No, we would run 3 pin in and 3 pin out if we were to daisy chain these.

I was thinking that we would pull the DMX cable through the J Box but not cut it until the alternate bid fixtures come into play and the contractor would make the splice in the J box then to the new fixtures.

I am meant to be receiving the T section spec sheet any moment now, so I will send it straight over and we will review together.

This could perhaps alleviate a lot of J boxes, we'll see.

Stand by.

Tracey Dear | tracey@dearproductions.com

Dear Productions Inc.

329 North Maple Avenue | Oak Park, IL 60302

Phone: (708) 445-0432 | Cell: (773) 294-1540

<http://www.dearproductions.com>

<unknown.jpg>

On Nov 1, 2019, at 10:28 AM, Leep, Jordan <Jordan.Lleep@kimley-horn.com> wrote:

Tracey,

This has generated a couple of additional questions... if the option would be a 3 pin does that mean that we do not have a + input and – input, and + output and – output? That would typically result in a 5 pin connector not a 3 pin correct? If that is the case do we need to update our splicing diagram?

In the configuration shown below my primary concern is that the connections would be spliced out in the open and not inside the junction box. I fear that could lead to maintenance issues in the future. I think we may need to revisit the framework to avoid wires in the open such as would be the case on the ends in this configuration.

Can you elaborate on the T section?

Jordan Leep P.E., PMP

Kimley-Horn | 1777 Main Street, Suite 200, Sarasota FL 34236

Direct: 941 379 7647 | Mobile: 906 869 2214

From: Tracey Dear [<mailto:tracey@dearproductions.com>]

Sent: Thursday, October 31, 2019 1:42 PM

To: Leep, Jordan <Jordan.Lleep@kimley-horn.com>

Cc: Rehm, Jacob <Jacob.Rehm@kimley-horn.com>

Subject: DMX Wiring

The Dyna Drum fixtures do not ship with 3 pin XLR connectors. It would cost an additional \$70 per fixture for them to be added.

So if we pull just DMX cable, we could go to the first fixture and then pull a data loop that would wrap around and go to the other side. For the alternate bid, the contractor would mount the extra fixtures and splice in the fixture off the loop.

The other news is that Acclaim have a new T section that sends Data in each direction which may be worth looking at as an alternative.

They are sending me a spec sheet on it.

<image001.jpg>

Tracey Dear | tracey@dearproductions.com

Dear Productions Inc.
329 North Maple Avenue | Oak Park, IL 60302
Phone: (708) 445-0432 | Cell: (773) 294-1540
<http://www.dearproductions.com>

<image002.jpg>

APPENDIX C: COMMENTS & RESPONSES



August 20, 2018

Ms. Anna Quinones
Engineering Specialist I
Tampa Hillsborough Expressway Authority
1104 East Twiggs Street, Suite 300
Tampa, FL 33602

RE: Initial Submittal Package Comments
Project: THEA Aesthetic Lighting

Our ref: 148872000

Dear Ms. Quinones:

We are in receipt of your email dated **May 3, 2018** in which corrections were requested on the above referenced project. The following are your comments in **bold**, followed by our responses:

- 1. A site survey of the existing load centers for compatibility should be performed prior to final design.**

Response: Kimley Horn conducted a field review of the existing load centers. After discussing with THEA maintenance staff, we were made aware that the ITS system experiences power issues where tied into existing lighting load centers. Consequently, it was decided the best path forward was to utilize new load centers.

- 2. Get utility upgrade listing from the DMS replacement project as soon as available.**

Response: Noted.

- 3. Provide additional details regarding the interface with the TMC and how this will tie to the existing system in future submittals (will we need the COT to review this part?)**

Response: See the ITS Plans for more details on how the Pharos controller will tie into the existing TMC system.

- 4. What are warranties recommended on the components? Recommend preparing a warranty special spec.**

Response: The luminaires come with a 5-year warranty. Warranty spec will need further coordination with THEA Staff. Multiple components may require various warranties.

- 5. Provide details on attachment of light fixtures to bridge components. Especially for straddle bents, end bents and RE Walls, also the location and type of fixtures for RE Walls.**

Response: See the Lighting plans for more details on how the bracket arms will be attached to the existing piers, walls, and straddle bents.

- 6. Structural Bracket Details: Provide details on how the brackets will be attached to piers/end bents and utilize a design wind speed of 150mph.**

Response: See the Lighting plans for more details on how the bracket arms will be attached to the existing piers, walls, and straddle bents.

- 7. Structural Bracket Details: How will the 90 degree bents / T-intersections / Connections with 4" diameter pipes be achieved? Will welding, threaded connections, or fasteners be utilized?**

Response: See the Lighting plans for more details on how the bracket arm attachments will be configured.

- 8. Structural Bracket Details: How will the brackets be protected against corrosion (Hot dip galvanized, painted, power coated) and what color will be specified?**

Response: All bracket arms will be galvanized steel. We have not specified a color for the fixtures or bracket arms. Specific color palettes need to be discussed in further detail.

- 9. Structural Bracket Details Straddle Bent: Verify that the luminaires do not violate the vertical clearance requirements over the LRSE.**

Response: The arm and fixtures will not be closer than 19' to the roadway which satisfies clearance requirements.

- 10. Page 8 of 47: How the Pharos controller is connected with the network and where it is located should be explained in future submittals.**

Response: See the ITS Plans for more details on how the Pharos controller will tie into the existing system. Final server pack location will need to be given to the design team.

- 11. Page 39 of 47: There is a callout for "existing pull boxes" at the fiber drops of each proposed lighting cabinet. Do these existing pull boxes need to be changed to proposed splice vaults?**

Response: No, the plan is to place a proposed splice enclosure inside existing pull boxes where there is already a splice into the Fiber Optic Backbone.

12. Page 42 of 47: The plan sheet calls out a “patch panel (as required).” Shouldn’t there be a patch panel at all cabinets?

Response: See the ITS plans for cabinet details. All cabinets will have an electrical connection panel and duplex receptacles.

If you have any additional questions, I can be reached by phone at 941.379.7600 or by email at jordan.leep@kimley-horn.com.

Sincerely,



Jordan E. Leep, P.E.
Project Manager

Attachment(s)

Project Name:

Project No: O-01217

Department:

Division:

Designer: KHA

Review Type: 90% Submittal

Description: Selmon Expressway Aesthetic Lighting - Lighting Plans

Date: 12/3/2019

Updated: 1/28/2020



Codes:

A. Agree w/ comment – will be corrected, added, or clarified.

D. Disagree w/ comment

(1) Indicate drawing no./page no. or use "G" for general comment.

(2) To be filled out by Designer.

(3) To be determined by THEA.

Item No	Page No ⁽¹⁾	Reviewer	Comment	Code ⁽²⁾	Response ⁽²⁾	Final Disposition ⁽³⁾
1	General	Johnson	Suggest a coordination note referencing possible concurrent work by Fiber to DMS Signs project. Just awarded.		Work was discussed to be nonconcurrent. No action.	
2	General	D. D'Antonio	Consider adding a detail or information identifying where the aboveground conduit is installed longitudinally along the bridge.		Disagree, Wiring Detail Bridge Deck Conduit Runs is sufficient for detailing the longitudinal runs within the REL box girder.	
3	39	D. D'Antonio	Please show legend for erosion control.		Agreed, a legend for erosion control has been added to Lighting Plan (25).	
4	Summary of Pay Items	D. Hubbard	Provide justification for using lump sum 4% for each MOT and Mobilization. These percentages typically range from 8% to 10% and there are several features presented in the TTC Plans such as pedestrian control, lane closures and work zone restrictions which could make these values higher than 4%.		The MOT and Mobilization approaches were discussed as simplistic enough that the current percentage was kept in the estimate as 4% each.	
5	2	D. D'Antonio	Please rectify the inconsistencies between Summary of Pay Items quantities and ITS Tabulation of Quantities Grand Total.		Several of the ITS Quantities overlap with Lighting Quantities. The cumulative total is shown in the engineers estimate/summary of pay items.	
6	7	D. D'Antonio	AC Electrical Conduit Sizing Table can be removed since all conduits are standard size with the exception of Load Center HH to Pier 65. This 2.5-in. conduit can be identified on the plan sheet.		Agreed, conduit sizes differing from standard 2" are now listed in the plans; the conduit sizing table has been removed.	
7	31	D. D'Antonio	Consider an alternate service point. The conduit shown seems to be through environmentally sensitive lands with standing water. Clarify is the intent is to directional bore the conduit under the waterbed.		Agreed, the service point has been relocated to avoid standing water.	
8	34	D. D'Antonio	Consider adding a callout for the inlet at Sta. 330+20, RT.		Agreed, the call-out at STA. 330+20 has been added.	
9	39	D. D'Antonio	Please graphically show conduit to be out of the retention area, preferably along the top of bank. Please consider a note for the contractor to place conduit and pull boxes out of ditch bottoms and in dry areas.		Agreed, the conduit location has been adjusted to be shown at the top of bank.	
10	40	D. D'Antonio	Please show the conduit running around the toll equipment building at Sta. 389. Please ensure that the building is not in conflict with the proposed light spacing.		Agreed, the conduit has been adjusted to run around the toll equipment building. A site visit confirmed that conduit must take this pattern as suggested in the comment. The light spacing along retaining walls has also been verified.	
11	54	D. D'Antonio	Please consider increasing the font size for the Acclaim splicing detail so that it is legible if reproduced. This conduit applies to multiple sheets.		Agreed, the Acclaim Splicing Detail has been upscaled to increase legibility.	
12	55	D. D'Antonio	Please consider requiring a plastic or rubber grommet in the 1" dia. holes to protect the cabling.		Agreed, a rubber grommet has been detailed in the plans.	
13	58	D. D'Antonio	What is the difference between the blue and grayed lines from the Acclaim outdoor link system? If no difference, consider using the same color. This comment applies to multiple sheets.		The blue lines show proposed outdoor link system, and grey represents link system pertaining to the other set of plans (base bid/bid alternate). Please see updated legends throughout plans to clarify.	
14	59	D. D'Antonio	How will the conduit transition from the straddle bent junction box to bridge attachment? Consider adding a detail.		Agreed, a detail has been added to show conduit transitioning from the straddle bent junction box, through the bottom slab of the box girder, and down through Structural Arm Type 5.	
15	59	D. D'Antonio	Please ensure consistency between plans and specifications regarding junction box sizes. The junction boxes are non-standard size per FDOT specifications. Are special provisions needed?		Agreed, a MSP has been created for non-standard junction box sizes.	
16	60	D. D'Antonio	Detail references splicing diagram A. Splicing Diagram A could not be located in the plans. Should sheet 61 be splicing diagram A?		Agreed, abutment wiring detail splicing diagram is now labeled as Splicing Diagram A.	

Project Name:

Project No: O-01217

Department:

Division:

Designer: KHA

Review Type: 90% Submittal

Description: Selmon Expressway Aesthetic Lighting - Lighting Plans

Date: 12/3/2019

Updated: 1/28/2020



Codes:

A. Agree w/ comment – will be corrected, added, or clarified.

D. Disagree w/ comment

⁽¹⁾ Indicate drawing no./page no. or use "G" for general comment.

⁽²⁾ To be filled out by Designer.

⁽³⁾ To be determined by THEA.

Item No	Page No ⁽¹⁾	Reviewer	Comment	Code ⁽²⁾	Response ⁽²⁾	Final Disposition ⁽³⁾
17	62	D. D'Antonio	Please ensure consistency with the specifications for flexible PVC conduit. FDOT spec. allows flexible conduit up to 6 ft. in length. If the runs will be longer than 6 ft., consider include a special provision. Please callout conduit material to the left of the center junction box.		Agreed, call-outs detailing conduit type have been updated so flexible conduit is not run in lengths longer than 6ft.	
18	63	D. D'Antonio	Add missing callout for proposed splice enclosure.		Agreed, the call-out has been added.	
19	66	D. D'Antonio	Consider modifying the pedestal removal callout to state, "Remove complete foundation." Bottom of the foundation may be ambiguous.		Agreed, "removal of exist. Luminaire detail" has been updated to show more accurate callouts and pay items.	
20	68	D. D'Antonio	Please adjust row height of Notes for legibility.		The MOT intent table has been removed and a single lane closure is called for in all MOT approaches.	
21	3 & 6	Johnson	Sheet 3 includes a grand total column but page 6 is the last sheet of tabulations. Need to move grand total column to sheet 6 and ensure grand total includes quantities from all sheets.		Agreed, the grand total column for the base bid and bid alt quantities has been moved to the last sheet of the quantities.	
22	Key Sheet	Al Stewart	Governing Design Standards reference the FY 2017-18 Design Standards eBook. Shouldn't the reference be to the applicable edition of the Standard Plans for Road and Bridge Construction?		Agreed, the Governing Design Standards has been updated as suggested.	
23	Key Sheet	D. Hubbard	Include begin/end project stationing and/or milepost information. Verify the "end project" callout is properly referenced on the key map.		Agreed, Begin/End Project Stationing has been added to the base bid and bid alt key sheets.	
24	Key Sheet	D. Hubbard	Indicate contract number on the key sheet. It should be O-01217 per the rest of the plans.		Agreed, the contract number has been added to the key sheet of both sets of plans.	
25	General Notes	Al Stewart	Please add a note to the General Notes with language similar to, "The Contractor is alerted that significant portions of the project contain underdrain stormwater treatment systems between the REL piers that must be maintained and continue to function during construction. Any damage to the existing systems will be replaced or repaired to the satisfaction of the Authority at the Contractor's expense."		Agreed, the general note has been added into both sets of plans.	
26	TTC - General	D. Hubbard	There are no lane closure restrictions provided. Provide a note indicating the following allowable lane closure times: Monday through Friday, 7 PM to 5 AM and 9 AM to 3:30 PM; Saturday, 7 AM through Monday, 5 AM.		Agreed, lane closure restrictions have been updated in the TTC plan sheets for both sets.	
27	TTC - General	D. Hubbard	There are no special event notes provided. Provide standard lane closure restriction note and include the following special events: All events at the Amalie Arena or Tampa Convention Center with an anticipated attendance of 10,000 or more. Include this on the general notes as well.		Agreed, a special events note for Amalie Arena and restricting eastbound traffic 1 hr after those events has been added to the TTC plans and general notes.	
28	TTC - General	D. Hubbard	Provide phasing notes and clarifications to indicate how the MOT and Access Point tables are intended to be applied. In addition, it appears Typical A and B are not necessary as they do not indicate the anticipated lane closures, so a phasing note indicating the work on shoulder index application would be more appropriate.		Agreed, the MOT Approach has been limited to single lane closures only.	
29	TTC - General	D. Hubbard	Provide justification for the REL Access Point table. Based on the typical sections provided the contractor may access the work zone at any point where it can be safely accessed, so is the table a necessary feature in the TTC Plans?		The REL Access Table has been renamed "REL Hatch Access Point Table." This is useful for contractor access into the REL box girder.	
30	67	D. Hubbard	Is Note 4 needed? Work being performed over the railways appears to be within the bridge segments, so it is not clear what purpose the construction netting is serving. Is there additional work over the railway which needs to be protected?		Agreed, note 4 has been removed.	
31	67	D. Hubbard	The typicals indicate varying shoulder width. It appears the intent is to maintain outside shoulder widths throughout construction, which needs to be indicated on the typicals. Is the contractor allowed to reduce the shoulder width to accommodate the typicals?		All shoulder width call-outs have been updated to say "exist. Shoulder."	

Project Name:

Project No: O-01217

Department:

Division:

Designer: KHA

Review Type: 90% Submittal

Description: Selmon Expressway Aesthetic Lighting - Lighting Plans

Date: 12/3/2019 Updated: 1/28/2020



Codes:

A. Agree w/ comment – will be corrected, added, or clarified.

D. Disagree w/ comment

(1) Indicate drawing no./page no. or use "G" for general comment.

(2) To be filled out by Designer.

(3) To be determined by THEA.

Item No	Page No ⁽¹⁾	Reviewer	Comment	Code ⁽²⁾	Response ⁽²⁾	Final Disposition ⁽³⁾
32	67	D. Hubbard	Are there any special precautions that need to be taken for construction over the Tampa Bypass Canal?		Contact has been initiated with the Port Authority.	
33	67	D. Hubbard	Revise the typicals to show the appropriate roadside treatments. The traffic railings shown are all temporary barrier wall segments and should be single-faced walls.		Type K barricade has been updated to a Type F Barrier wall.	
34	68	D. Hubbard	Please explain the "MOT Intent Table" shown on sheet 68 to properly indicate how this is to be applied by the contractor. It looks as though the intention is to apply different typicals at different locations throughout the corridor, but shouldn't that be done per phase? Also how are the different typicals transitioned during construction? It looks like there either needs to be phase descriptions or phasing plans because this isn't enough information to lay out a work zone.		The MOT intent table has been removed and a single lane closure is called for in all MOT approaches.	
35	68	D. Hubbard	MOT Intent Table Note does not provide clear direction. Is the "Direction of Travel" column supposed to indicate the access direction? How does this work with the typical sections provided, where it seems that access could be from either direction of travel?		The MOT intent table has been removed and a single lane closure is called for in all MOT approaches.	
36	69	D. Hubbard	The plan note indicates pedestrian control signage and sidewalk diversions. What is the purpose of this note and are there additional details needed? Provide the expected application for this access control and any necessary details to clarify the design intent.		The design intent discussed at the 90% Submittal meeting was to cross pedestrians to the other side of Channelside drive during pier 168 or 169 construction. A pedestrian detour graphic has been added to the TTC plan sheet.	
37	69	D. Hubbard	Consider revising the "Shoulder Work" signs to "Left Lane Closed" to be in place while under lane closure. Review and revise the details to avoid conflicts with standard MOT signage under the Index 600 series applications.		The MOT Approach has been limited to single lane closures only.	
38	Pole Data & Legend	S. Parajuli	Consider providing luminaire wattage information on this sheet.		Luminaire wattage information can be found on the cut sheets or voltage drop calculations.	
39	Lighting Plans Sheet 15 & 16 (Base Bid)	S. Parajuli	Consider clarifying the callout to indicate that 14 luminaires @19' and 2 luminaires @70' are proposed from sta. 106+48.0 to sta. 110+35.0. Include "Start" and "End" to the callouts to make it more clear. (Typical)		Agreed, Begin and End callouts have been added to the retaining walls.	
40	Lighting Plans Sheet 22 (Base Bid)	S. Parajuli	Consider clarifying the callouts to indicate that 11 luminaires @19' and 2 luminaires @70' are proposed from sta. 178+92.5 to sta. 182+22.5. (Typical comment to all the callouts similar to these)		Agreed, Begin and End callouts have been added to the retaining walls.	
41	Lighting Plan Sheet 19 (Alternate Bid)	S. Parajuli	It appears that Alternate Bid does not propose luminaires on any of the retaining wall. Is there are reason why?		All work on retaining walls is to be done in the base bid.	
42	42	J. Gutierrez/C. Boyd	The fabrication details for the Structural Arm Type 5 shown on Sheet 50 show the base plates welded to the 3x3 structural tube uprights. How will these baseplates be attached to the inside of the bottom slab of the segmental box girder using the details shown in the "STRUCTURAL ARM TYPE 5 DETAIL" if the holes through the bottom flange are large enough for the base plates to pass through?		Agreed, the bolt directions in Structural Arm Type 5 detail have been changed to show baseplates being proposed to attach to the outside/inside of the bottom slab, and the bolts connecting through the bottom soffit of the box girder.	
43	42	J. Gutierrez/C. Boyd	The base plate attachment details shown conflict with those shown on Sheet 50.		Agreed, base plate attachment details have been updated.	
44	42	J. Gutierrez/C. Boyd	Given that the overall height of the Structural Arm Type 5 is not shown on Sheet 50, has the remaining vertical clearance beneath the proposed structural arm been confirmed to meet current requirements at all planned installation locations?		Agreed, minimum vertical clearances at Structural Arm Type 5 (Straddle Bent) locations are met per AASHTO and FHWA standards.	
45	42	J. Gutierrez/C. Boyd	The longitudinal location of the Structural Arm Type 5 along the bridge (distance from centerline straddle pier) is not shown.		Agreed, the longitudinal location of Structural Arm Type 5 is now shown on sheet 43.	
46	42	J. Gutierrez/C. Boyd	The vertical location of the Structural Arm Type 3 (Type 4?) on the pier columns is not shown.		Agreed, the vertical location of each is now shown.	

Project Name:

Project No: O-01217

Department:

Division:

Designer: KHA

Review Type: 90% Submittal

Description: Selmon Expressway Aesthetic Lighting - Lighting Plans

Date: 12/3/2019 Updated: 1/28/2020



Codes:

A. Agree w/ comment – will be corrected, added, or clarified.

D. Disagree w/ comment

(1) Indicate drawing no./page no. or use "G" for general comment.

(2) To be filled out by Designer.

(3) To be determined by THEA.

Item No	Page No ⁽¹⁾	Reviewer	Comment	Code ⁽²⁾	Response ⁽²⁾	Final Disposition ⁽³⁾
47	43	J. Gutierrez/C. Boyd	The connection details shown in the "STRUCTURAL ARM TYPE 5 SIDE VIEW" will require holes to be cut through the bottom slab of the segmental box girder for the vertical supports to pass through. However, no details are shown for drilling or cutting such holes.		Agreed, details have been added to show the drilling required to pass through the bottom slab on sheet 50.	
48	43	J. Gutierrez/C. Boyd	The base plate attachment details shown conflict with those shown on Sheet 50.		Agreed, base plate attachment details have been updated on sheets 43 and 50.	
49	44	J. Gutierrez/C. Boyd	What is the difference between a "Structural Arm Type 3" shown on this sheet and a "Structural Arm Type 4" shown on Sheet 45?		Type 3 utilizes mounting plate type 2, whereas Type 4 uses mounting plate type 1. Please see structural arm detail luminaire mounting plate sheet for type 1 mounting plate vs. type 2 mounting plate.	
50	44	J. Gutierrez/C. Boyd	The 17'-9" center to center dimension shown between the Structural Arm Type 1s conflicts with the 4'-0" dimension shown between these arms on Sheet 49.		Agreed, extra detail has been provided to show the varying spacing between Structural Arm Type 1 members for the pier/abutment.	
51	44	J. Gutierrez/C. Boyd	In the view at the top of the sheet, what is a "Mounting Plate Type 2"?		Please see "Structural Arm Detail Luminaire Mounting Plate" sheet for mounting plate details.	
52	45	J. Gutierrez/C. Boyd	In the view at the top of the sheet, what is a "Mounting Plate Type 2"?		Please see "Structural Arm Detail Luminaire Mounting Plate" sheet for mounting plate details.	
53	45	J. Gutierrez/C. Boyd	STRUCTURAL ARM TYPE 4 SIDE VIEW: a) The concrete traffic railing is incorrectly shown as a single slope traffic railing. b) What is the 8" dimension meant to convey? It is not drawn to the centerline of the light fixture.		Agreed, STRUCTURAL ARM TYPE 4 SIDE VIEW has been updated to reflect the correct railing and spacing of luminaire on the base plate.	
54	48	J. Gutierrez/C. Boyd	Has approval to use field drilled holes in the piers been obtained from the THEA Director of Expressway Operations, instead of District Structures Design Engineer as required by SDG 1.9?		Please see "2020-01-16 THEA Aesthetic Lighting Concept Review" in Correspondance section of LDAR for Kimley-Horn connection recommendations.	
55	48	J. Gutierrez/C. Boyd	Materials Note 2.B: The use of ASTM A36 conflicts with the requirements of SDG 5.3.1.A and Specifications Section 962.		Agreed, materials note 2 reflects ASTM A709, Grade 60.	
56	48	J. Gutierrez/C. Boyd	Materials Note 3.IV: No details are shown in the plans where reinforcing steel would be required. Please confirm the need for this note.		Agreed, note deleted.	
57	48	J. Gutierrez/C. Boyd	Materials Note 4A: How can bolt diameter be equal to bolt diameter plus 1/8"? If this intended to be the hole diameter in steel components, it conflicts with the hole diameter for the post clamps and vertical posts called for on Sheet 49.		Agreed, note was revised to say "Bolt hole diameter plus 1/8".	
58	48	J. Gutierrez/C. Boyd	Materials Note 4B: How can bolt diameter be equal to bolt diameter plus 3/4"? If this is intended to be the anchor bolt hole diameter in the baseplates and post clamps, it conflicts with the hole diameter called for on Sheet 49. If it is intended to be the drilled hole diameter in the concrete member, it conflicts with the requirements of SDG 1.6.1.C.		Agreed, note was revised to say "Bolt hole diameter to follow manufacturer's recommendations and shall comply with Section 416 & 937 of the Specifications".	
59	48	J. Gutierrez/C. Boyd	Materials Note 5A conflicts with the requirements of Specification Section 962-9.2 and the Coatings note on Sheet 49.		Agreed, removed note 5A from fabrication - note 2 and placed page 49 Coatings note under fabrication - note 2 in general notes.	
60	48	J. Gutierrez/C. Boyd	Materials Note 5B conflicts with the Coatings note on Sheet 49.		Agreed, removed note 5B from fabrication - note 2 and placed page 49 Coatings note under fabrication - note 2 in general notes.	
61	49	J. Gutierrez/C. Boyd	Has approval to use field drilled holes in the piers been obtained from the THEA Director of Expressway Operations, instead of District Structures Design Engineer as required by SDG 1.9?		Please see "2020-01-16 THEA Aesthetic Lighting Concept Review" in Correspondance section of LDAR for Kimley-Horn connection recommendations.	
62	49	J. Gutierrez/C. Boyd	The components shown are not labeled as Structural Arm Type 1 and Type 2.		Agreed, callouts have been added on pg 49 for type 1 and type 2 arms.	

Project Name:

Project No: O-01217

Department:

Division:

Designer: KHA

Review Type: 90% Submittal

Description: Selmon Expressway Aesthetic Lighting - Lighting Plans

Date: 12/3/2019

Updated: 1/28/2020



Codes:

A. Agree w/ comment – will be corrected, added, or clarified.

D. Disagree w/ comment

(1) Indicate drawing no./page no. or use "G" for general comment.

(2) To be filled out by Designer.

(3) To be determined by THEA.

Item No	Page No ⁽¹⁾	Reviewer	Comment	Code ⁽²⁾	Response ⁽²⁾	Final Disposition ⁽³⁾
63	49	J. Gutierrez/C. Boyd	The vertical position of the Structural Arm Type 1 relative to the top of the pier as shown conflicts with that shown on Sheets 41 and 51.		Agreed, the vertical position of structural arm type 1 relative to the pier on page 49 has been updated to at least 2'-6".	
64	49	J. Gutierrez/C. Boyd	The 4'-0" center to center dimension shown between the Structural Arms Type 1 conflicts with the 17'-9" dimension shown between these arms on Sheet 44.		Agreed, center dimension of section A-A reflects "Varies (see note 4)."	
65	49	J. Gutierrez/C. Boyd	Relative vertical positions of the anchor bolts and 3/8" bolts are not consistent between DETAIL 1 and SECTION A-A.		Agreed, the placements of the bolts have been matched to reflect section A-A.	
66	49	J. Gutierrez/C. Boyd	The details shown in SECTION A-A conflict with where the section is taken in DETAIL 1.		Agreed, the section cut has been corrected.	
67	49	J. Gutierrez/C. Boyd	Horizontal position of the centermost 1/4" plate is not shown in Section A-A.		Agreed, the horizontal dimension is shown for the plate.	
68	49	J. Gutierrez/C. Boyd	The size of the 3/8" diameter bolts specified to connect the vertical posts to the post clamps conflicts with the requirements of ASTM F3125. The smallest bolt diameter covered by ASTM F3125 is 1/2".		Agreed, the diameter bolt has been changed to 1/2".	
69	49	J. Gutierrez/C. Boyd	Do all the adhesive bonded anchor bolts comply with the sustained tension limits stated in SDG 1.6.2.B?		The adhesive bonded anchor bolts comply with the sustained tension limits stated in SDG 1.6.2. Calculations of the adhesive bonded anchor bolts can be found in the design calculation book under the Section titled "Connection Design"	
70	49	J. Gutierrez/C. Boyd	VERTICAL POST CLAMP CONNECTION DETAIL: a) Per SDG 1.6.1.C, drilled hole diameters in the concrete are to be based on the recommendations of the adhesive bonding material manufacturer. Note that these recommendations vary by product and manufacturer. b) The concrete component that the structural arm is to be attached to is labeled "Pier" but this detail is also applicable to the End Bent abutment.		a) Agreed, note has been added to reflect this comment on pg 49, b) Agreed, the call-out has been changed to reflect both pier and abutment.	
71	49	J. Gutierrez/C. Boyd	Have the positions of the proposed anchor bolts been checked to confirm there will not be any conflicts with existing reinforcing steel in the pier? The anchor bolt spacing shown on this sheet conflicts with the spacing shown on 90% Submittal_THEA_LDAR_Base Bid, PDF Pages 123 and 124 of 531.		The location of the reinforcing steel is to be confirmed prior to anchor bolt placement. Refer to general notes attachment notes- note 1.	
72	49	J. Gutierrez/C. Boyd	Weld symbols as shown are not consistent with AWS standard practice. See the Structures Detailing Manual for requirements.		Weld symbols have been modified to be consistent with AWS Standards.	
73	49	J. Gutierrez/C. Boyd	The structural arm is shown to be rigidly constructed and existing reinforcing steel is not allowed to be cut per Materials Note 8A on Sheet 48. Given this combination, how can the arm be shifted to comply with Note 8A if reinforcing steel is only encountered when drilling an anchor bolt hole at one location?		Agreed, the arms will include slotted holes for anchor bolt adjustment, refer to clamp detail on page 49.	
74	49	J. Gutierrez/C. Boyd	The wording of the "****" note is not appropriate for use in a plan set. This dimension must be confirmed by the designer.		Agreed. The "****" has been replaced with a "1" min".	
75	50	J. Gutierrez/C. Boyd	Has approval to use field drilled holes in the segmental box girder and straddle bent pier columns been obtained from the THEA Director of Expressway Operations, instead of District Structures Design Engineer as required by SDG 1.9?		Please see "2020-01-16 THEA Aesthetic Lighting Concept Review" in Correspondance section of LDAR for Kimley-Horn connection recommendations.	
76	50	J. Gutierrez/C. Boyd	Weld symbols as shown are not consistent with AWS standard practice. See the Structures Detailing Manual for requirements.		Weld symbols will be modified as per Structures Detailing Manual Requirements.	
77	50	J. Gutierrez/C. Boyd	The wording of the "****" note is not appropriate for use in a plan set. This dimension must be confirmed by the designer.		Agreed. The "****" has been replaced with a "1" min".	
78	50	J. Gutierrez/C. Boyd	The "PLAN VIEW" callout is not in the correct location on the sheet.		Agreed, the call-out location has been updated.	

Project Name:

Project No: O-01217

Department:

Division:

Designer: KHA

Review Type: 90% Submittal

Description: Selmon Expressway Aesthetic Lighting - Lighting Plans

Date: 12/3/2019

Updated: 1/28/2020



Codes:

A. Agree w/ comment – will be corrected, added, or clarified.

D. Disagree w/ comment

(1) Indicate drawing no./page no. or use "G" for general comment.

(2) To be filled out by Designer.

(3) To be determined by THEA.

Item No	Page No ⁽¹⁾	Reviewer	Comment	Code ⁽²⁾	Response ⁽²⁾	Final Disposition ⁽³⁾
79	50	J. Gutierrez/C. Boyd	BASEPLATE DETAIL: a) Hole diameters for anchor bolts are not shown. B) Horizontal dimensions of holes are not shown.		Agreed, a) hole diameters are now shown b) horizontal dimensions are now shown.	
80	50	J. Gutierrez/C. Boyd	STRADDLE BENT MIDDLE detail: a) The use of overhead installations of adhesive bonded anchors as shown in Section A-A is not permitted per SDG 1.6.2.B. b) The details shown in Section A-A conflict with where the section is taken. c) The overall height of the assembly is not shown. d) Are there any potential conflicts between the anchor bolts and reinforcing steel and PT tendons and/or anchorages within the segmental box girder? e) How are the ¼" plates attached to the horizontal HSS tubes? f) The structural arm is shown to be rigidly constructed and existing reinforcing steel is not allowed to be cut per Materials Note 8A on Sheet 48. Given this combination, how can the arm be shifted to comply with Note 8A if reinforcing steel is only encountered when drilling an anchor bolt hole at one location?		A) An additional baseplate has been added to the top of the segmental box girder bottom flange, B) Agreed, callout section A-A removed and replaced by "straddle bent middle- elevation view", C) The heights are shown on "Structural Details" sheets corresponding to each placement, D) Potential conflicts to be field verified, E) The plates are to be welded to the horizontal tubes, F) Include slot for adjustment refer to page 50 note 2.	
81	50	J. Gutierrez/C. Boyd	ABUTMENT, STRADDLE BENT-SIDES, AND RETAINING WALL detail: a) The item is not labeled as "Structural Arm Type 3" or "Structural Arm Type 4". b) The view is not labeled as a plan view. c) The column is mislabeled as a "Straddle Bent". d) The details shown in SECTION B-B conflict with where the section is taken. e) Thickness of the baseplates is not shown. f) Per SDG 1.6.1.C, drilled hole diameters in the concrete are to be based on the recommendations of the adhesive bonding material manufacturer. Note that these recommendations vary by product and manufacturer. g) Do all the adhesive bonded anchor bolts comply with the sustained tension limits stated in SDG 1.6.2.B? h) Are there any potential conflicts between the anchor bolts and reinforcing steel within the piers? i) The structural arm is shown to be rigidly constructed and existing reinforcing steel is not allowed to be cut per Materials Note 8A on Sheet 48. Given this combination, how can the arm be shifted to comply with Note 8A if reinforcing steel is only encountered when drilling an anchor bolt hole at one location?		a) Agreed, callout has been changed to reflect arm type 3 or 4, b) Agreed, the view has been labeled plan view, c) Agreed, the note is reworded to demonstrate all three details, d) Agreed, the cut has been moved to correctly show section B-B, e) Agreed, the thickness has been added, f) Agreed, note has been added on page 50, g) Tension limits will be verified, h) Potential conflicts to be field verified, i) Include slot for adjustment refer to page 50 note 2.	
82	52	J. Gutierrez/C. Boyd	How will the proposed H-frame, junction boxes and conduits be attached to the inside of the segmental box girder?		Please refer to updated ITS plans for H-frame attachment and new lighting plans sheet with conduit and junction box connections.	
83	55	J. Gutierrez/C. Boyd	How and where will proposed conduits and junction boxes be attached to the inside of the segmental box girder?		Please refer to new lighting plan sheet with conduit and junction box connections.	
84	55	J. Gutierrez/C. Boyd	An opening is shown in the top of the right-side vertical post which implies the proposed link system wiring is intended to be installed within the support bracket. However, no such opening or other any other openings are shown in the details on Sheet 49 for this to be possible.		Agreed, callout has been added to sheet 49 and note 2 to refer to wiring details.	
85	68	J. Gutierrez/C. Boyd	MOT Typical B does not appear to be applicable to the installation of light support brackets at Straddle Piers 26L through 29L. Please confirm.		Light installations will be accomplished via single lane closures as discussed in the 90% Submittal Meeting.	
86	68	J. Gutierrez/C. Boyd	MOT Typical C does not appear to be applicable to the installation of light support brackets at Straddle Piers 42L through 46L. Please confirm.		Light installations will be accomplished via single lane closures as discussed in the 90% Submittal Meeting.	
87	68	J. Gutierrez/C. Boyd	MOT Typical A is not applicable to the installation of light support brackets at Straddle Piers 162L through 165L.		Light installations will be accomplished via single lane closures as discussed in the 90% Submittal Meeting.	

Project Name:

Project No: O-01217
 Department:
 Division:
 Designer: KHA
 Review Type: 90% Submittal
 Description: Selmon Expressway Aesthetic Lighting - ITS Plans
 Date: 12/3/2019



Codes:

- A. Agree w/ comment – will be corrected, added, or clarified.
- D. Disagree w/ comment

- (1) Indicate drawing no./page no. or use "G" for general comment.
- (2) To be filled out by Designer.
- (3) To be determined by THEA.

Item No	Page No ⁽¹⁾	Reviewer	Comment	Code ⁽²⁾	Response ⁽²⁾	Final Disposition ⁽³⁾
1	General	Johnson	This project adds significant splices in the THEA backbone. Suggest requiring that only assigned buffer be broken out and all others continue.		Agreed, we have coordinated with THEA to use four fibers of the brown buffer for this project and have performed an OTDR on the brown buffer to verify fibers 1-4 are continuous throughout the project limits. The splice diagram on IT-27 has been updated to show all splicing being performed on fibers 1-4 of the brown buffer and all other buffers are now shown as closed and continuous.	
2	IT-7	Johnson	Need general note referencing as-builts or other reference plans that show existing fiber optic path. These ITS plans do not show existing path.		Agreed, the plans now show the existing fiber optic path.	
3	IT-7	Johnson	Need general note referencing existing fiber and conduit path is located within the interstitial of the bridge, which constitutes confined space. Contractor to provide environmental testing prior to each period of work to ensure that entry falls within "no permit required" parameters. Contractor to provide a "competent person" for testing and monitoring of environment, and supervision of crews involved in confined space work.		Agreed, a general note has been added into the ITS plans to satisfy this comment.	
4	IT-7	Johnson	Pay item note 676-2-111 makes H-frame inclusive of this pay item. However Engineer's Estimate calls out the H-frame by FDOT pay item. May not be significant but recommend review.		Agreed, the pay item note has been removed from these plans. The lighting plans account for the H-frame quantity as a separate pay item in the engineers estimate since some ITS cabinets appear to be outside the REL.	
5	IT-4	D. D'Antonio	The tabulation of quantities grand total does not match the summary of pay items totals. Please review.		Please note that the ITS quantities are included within the engineers estimate, additional to the lighting plan quantities.	
6	IT-8 - IT-29	D. D'Antonio	Please fix all duplicative curve data callouts and conflicts.		Agreed, all duplicate curve data and text conflicts have been corrected.	
7	IT-27	D. D'Antonio	Please review the proposed splice enclosure callouts and linework. Should be solid and legend should match label at the bottom of the symbol. Please show fiber drop cable entering the enclosure and unterminated. Fiber strands will be provided to the consultant.		Agreed, sheet IT-27 has been updated to show solid splice enclosures, naming to match the legend, and new fiber strand connections.	
8	IT-28	D. D'Antonio	Consider revising the Pier Light Fixtures titles since all fixtures are not pier-mounted. Some are wall-mounted.		Agreed, the term "pier light fixtures" has been updated to say "luminaire arrays."	
9	Key Sheet	D. Hubbard	THEA Project Manager does not match the lighting plans. Please reconcile.		Agreed, THEA PM on the key sheet has been updated to be Judith Villegas.	
10	IT-29	J. Gutierrez/C. Boyd	How will the proposed H-frame and conduit be attached to the inside of the segmental concrete box girder?		Agreed, IT-29 now shows an epoxy based anchorage piece and conduit straps to hold the proposed ITS components.	
11	IT-29	J. Gutierrez/C. Boyd	The terms "bridge floor" and "bridge ceiling" are not standardized names for these parts of a segmental concrete box girder. See SDG 4.6 and SDM Chapter 20 for requirements.		Agreed, the terms have been updated to say "Top Slab of REL" and "Bottom Slab of REL."	

Project Name:

Project No: O-01217
 Department:
 Division:
 Designer: KHA
 Review Type: 90% Submittal
 Description: Selmon Expressway Aesthetic Lighting - LDAR
 Date: 12/3/2019



Codes:

- A. Agree w/ comment – will be corrected, added, or clarified.
- D. Disagree w/ comment

- ⁽¹⁾ Indicate drawing no./page no. or use "G" for general comment.
- ⁽²⁾ To be filled out by Designer.
- ⁽³⁾ To be determined by THEA.

Item No	Page No ⁽¹⁾	Reviewer	Comment	Code ⁽²⁾	Response ⁽²⁾	Final Disposition ⁽³⁾
1	3	S. Parajuli	Revise street name to Twiggs St. instead of avenue.		Agreed, the street name has been updated to Twiggs St.	
2	Voltage Drop Calculations Load Center AA Ckt. 1	S. Parajuli	Please clarify how the loads are calculated. Are they based on Alternate Bid? These values do not seem to reflect Alternative Bid. Is it beneficial to provide a sample calculation? (Typical.)		The voltage drop calculations consider the final design conditions for each load center, which includes both the base bid and bid alternate luminaires/cabinets.	
3	Voltage Drop Calculations Load Center AA Ckt. 1	S. Parajuli	Consider matching load center stations with the plans. (Typical)		Agreed, the load center stations have been updated to match the plans.	
4	Voltage Drop Calculations Load Center AA Ckt. 2	S. Parajuli	Please make sure distance matches the plans. (Typical)		Agreed, the distances, wattages, and calculations have been checked and updated. The distances will not always match the plans exactly, as there are vertical distances and distances considered to route the conductors through/along the structures needed for accurate calculations.	
5	Voltage Drop Calculations sheets	S. Parajuli	Consider removing pages with no calculations on it.		Agreed, blank pages have been removed.	

Project Name:

Project No: O-01217
 Department:
 Division:
 Designer: KHA
 Review Type: 90% Submittal
 Description: Selmon Expressway Aesthetic Lighting - Estimate and Specifications
 Date: 12/3/2019



Codes:

- A. Agree w/ comment – will be corrected, added, or clarified.
- D. Disagree w/ comment

- ⁽¹⁾ Indicate drawing no./page no. or use "G" for general comment.
- ⁽²⁾ To be filled out by Designer.
- ⁽³⁾ To be determined by THEA.

Item No	Page No ⁽¹⁾	Reviewer	Comment	Code ⁽²⁾	Response ⁽²⁾	Final Disposition ⁽³⁾
1	Specs - G	D. Hubbard	The special provisions include several instances of referring to the Department. Review the specifications and include appropriate reference to the Authority where applicable.		Agreed, the Authority is now referenced in all appropriate cases where the Department was previously.	
2	Specs - 4	D. Hubbard	Proposal requirements and conditions provision refers the the Department's website. Revise this special provision to direct questions to Man Le and the Authority.		Agreed, Man Le and the Authority is now the updated contact for direct questions.	
3	Specs - 12	D. Hubbard	Contaminated materials special provision refers to the District VII Environmental/Hazardous Materials Administrator. This should be referred to the Authority.		Agreed, the Authority is now referenced in all appropriate cases where the Department was previously.	
4	Estimates	D. Hubbard	Provide backup information justifying the 4% for mobilization and MOT. These percentages seem low considering the lack of quantities shown for MOT pay items.		The MOT and Mobilization approaches were discussed as simplistic enough that the current percentage was kept in the estimate as 4% each.	
5	Estimates	D. Hubbard	Include pay item quantities for MOT features which can be calculated based on the phase typicals and the advanced warning signage. This commonly includes 102-99, 102-60/102-62, 710, 102-76, 102-74, etc.		Disagree, MOT features will be paid for under 101-1 and 102-1 and not broken out unless discussed otherwise.	
6	Estimates	S. Parajuli	Are the unit costs for these pay items reasonable? They are significantly lower than FDOT unit costs. 630-2-15A, 635-2-13, 639-6-1, 715-5-41, 715-5-42, 715-5-43, 715-5-44, 715-5-45.		Agreed, the pay items mentioned have been reviewed for accuracy to the scope of the project. Please note that pay items 715-5-43 and 715-4-44 have been reduced. These items previously paid for the whole assembly (two arms, base plate, connection components), but the quantity is based on each arm. The price now considers one steel arm, one connection point, and half of the mounting plate to calculate a more accurate total cost. Please note that all Structural arm pay items also consider the cost of manufacturing, powder coating, and installation.	
7	Estimates	S. Parajuli	Provide pay item notes for the pay items not identified in Basis of Estimates. Consider including specific items that should be covered in these pay items.		Agreed, a pay item note has been included on the general notes sheet to detail what is inclusive in the cost of the structural arms.	

Project Name:

Project No: O-01217

Department:

Division:

Designer: KHA

Review Type: 100% Submittal

Description: Selmon Expressway Aesthetic Lighting - Lighting Plans

Date:



Codes:

A. Agree w/ comment – will be corrected, added, or clarified.

D. Disagree w/ comment

⁽¹⁾ Indicate drawing no./page no. or use "G" for general comment.

⁽²⁾ To be filled out by Designer.

⁽³⁾ To be determined by THEA.

Item No	Page No ⁽¹⁾	Reviewer	Comment	Code ⁽²⁾	Response ⁽²⁾	Final Disposition ⁽³⁾
1	42		The vertical location of the Structural Arm Type 3 on the pier columns is not shown.	B	The vertical location of Structural Arm Type 3 on the straddle bent column is shown in the side view on sheet 43.	
2	43		1. Structural Arm Type 5 Side View: The 3 foot length of the vertical member is dimensioned to the top of the bottom slab (inside) of the box girder, not the bottom (outside) of the box girder. Please confirm.	A	Confirmed. This provides roughly 2'- 2 1/2" of space between the bottom (outside) and horizontal member of the structural arm Type 5.	
			2. Has the remaining vertical clearance beneath the proposed structural arm been confirmed to meet current the 17.5' clearance requirement per FDM 210.10.3 at all planned installation locations?	A	Agreed, a vertical clearance report has been added to the design doc report.	
3	44		1. Why is a table of variables used for dimensions AA, DD and EE if these dimensions do not vary between Abutments 1, 123 and 124?	A	Agreed, the table of variables has been updated to remove dimension AA, but keep DD and EE to show when the luminaires are not present on certain abutments. Bid alternate plans have been checked with the same intention.	
			2. What is the difference between a "Structural Arm Type 3" shown on this sheet and a "Structural Arm Type 4" shown on Sheet 45?	B	Structural arm Type 3 utilizes mounting plate type 2 as indicated in the plans, whereas Structural arm Type 4 utilizes mounting plate type 1. Please see Structural Arm Detail Luminaire Mounting Plate for more information.	
4	45		Structural Arm Type 4 Side View:			
			1. Mounting the baseplate level with the bottom of the traffic railing results in less than 1" of concrete between the top edge of the uppermost drilled holes and the top of the concrete coping. This small amount of concrete will likely spall as the holes are drilled.	A	Agreed, the base plate has been shifted downward to avoid potential spalling. Please see updated dimension.	
			2. The structural arm is shown to be rigidly constructed on Sheet 50 and existing reinforcing steel is not allowed to be cut per Attachment Notes 1 and 4 on Sheet 48. Have the positions of the anchor bolts been compared to the existing vertical and horizontal reinforcing in the MSE wall coping to determine if the requirements of Notes 1 and 4 can be met? Note that when this project was constructed, the reinforcing within MSE wall copings varied between the various retaining wall suppliers.	A	The structural arm detail on sheet 50 has been modified to reduce the number of adhesive anchors from eight (8) to four (4); thus, reducing the risk of a conflict with the existing steel reinforcement. Also, slotted holes will be provided to allow tolerance in case of a conflict between the adhesive anchors and the existing reinforcing steel.	
5	48		1. Materials Note 2: ASTM A709 does not contain criteria for Grade 60 steel.	A	Correct, the grade is 36 per SDG 5.3.1.A.	
			2. Fabrication Note 1.A: The bolt diameter is required to be bolt hole diameter plus 3/4". Please confirm. If this is intended to be the anchor bolt hole diameter in the baseplates and post clamps, it conflicts with the slotted holes called for on Sheet 49. If it is intended to be the drilled hole diameter in the concrete member, it conflicts with the requirements of SDG 1.6.1.C and Note 3 on Sheets 49 and 50.	A	The bolt hole diameter has been changed to bolt hole diameter plus 1/16".	
			3. Structure Erection – General Requirements: These three notes appear to be geared towards construction of a bridge, not installation of relatively small and lightweight luminaire support brackets.	A	Agreed. Notes will be modified to be geared towards the erection of a relatively small and lightweight luminaire support brackets.	
			4. General Architectural Project Note 1: The last sentence conflicts with FDOT standard practice.	A	Correct, the sentence has been removed.	

Project Name:

Project No: O-01217
 Department:
 Division:
 Designer: KHA
 Review Type: 100% Submittal
 Description: Selmon Expressway Aesthetic Lighting - Lighting Plans
 Date:



Codes:

- A. Agree w/ comment – will be corrected, added, or clarified.
- D. Disagree w/ comment

- ⁽¹⁾ Indicate drawing no./page no. or use "G" for general comment.
- ⁽²⁾ To be filled out by Designer.
- ⁽³⁾ To be determined by THEA.

Item No	Page No ⁽¹⁾	Reviewer	Comment	Code ⁽²⁾	Response ⁽²⁾	Final Disposition ⁽³⁾
6	49		1. Detail 1: Labeling of Structural Arm Type 2 conflicts with that shown on Sheet 41.	A	Correct, the labeling of arm types will match page 41.	
			2. Note 2: What hole is this note referring to?	A	Note 1 has been reworded to reference the wiring schematic. Hole locations have been updated on the sheet.	
			3. Note 4: Center to center dimension between the Structural Arms Type 1 is not shown on the Structural Arm Detail Pier sheet.	A	Agreed, the dimension will be shown.	
			4. Note 5: No holes are shown on the horizontal posts in Section A-A. Which holes should this note refer to? Which direction(s) would these slotted holes be oriented?	A	Agreed, Note 3 has been reworded to clarify slotted hole placement.	
			5. A plan note requiring pullout tests for the anchor bolts that are in sustained tension is not included.	B	Epoxy anchors in sustained tension will be replaced with undercut anchors; therefore, pullout tests will no longer be required.	
			6. Horizontal position of the centermost 3/4" plate is not shown in Section A-A.	A	Agreed, the dimension will be shown.	
			7. The thickness of the Post Clamp is not shown. Is the Post Clamp intended to be a single bent plate or fabricated from multiple smaller plates? For a single bent plate, has the inside bending radius at the corners been compared to the shape of the HSS?	A	Agreed, the dimension will be shown. The post clamp is intended to be a single plate. The radius for the post clamp will match the HSS radius.	
			8. References to "Pier" will have to be deleted from this sheet when new structural arm details for use on pier columns are developed.	A	Agreed, the references will be deleted.	
			9. 1 1/2" diameter exit holes and holes between welded HSS members for wiring are not shown. Note that some exit holes are shown on Sheet 56 but the holes between welded HSS members are not.	A	Correct, the exit holes and holes between welded HSS members will be shown.	
			10. Additional access holes to facilitate wire pulling around the 90 degree corners are not shown at the welded connections between the HSS members.	A	Correct, the exit holes and holes between welded HSS members will be shown.	
			11. The structural arm is shown to be rigidly constructed and existing reinforcing steel is not allowed to be cut per Attachment Notes 1 and 4 on Sheet 48. Given this combination, how can the arm be shifted to comply with Notes 1 and 4 if reinforcing steel is only encountered when drilling an anchor bolt hole at one location?	A	Slotted holes have been provided at both vertical post clamps to be able to shift anchors to avoid existing steel reinforcement.	
7	50		1. Straddle Bent Middle (Elevation View):			
			a. The bolts are labeled as adhesive bonded anchors but are shown as through bolts.	A	Agreed, bolts are thru-bolts.	
			b. Recommend requiring the use of lock washers or self-locking nuts to reduce the potential for the connections to loosen due to traffic and wind induced vibrations.	A	Agreed, self-locking nuts will be used on the straddle bent middle.	
			c. The diameter of the anchor bolt holes that are to be drilled in the box girder bottom slab is not shown.	A	Agreed, the dimension will be shown.	
			d. The overall height of the assembly is not shown.	B	The overall height of the assembly is shown on sheet 43.	
			2. Straddle Bent Middle (Plan View):			
			a. The structural arm is shown to be rigidly constructed and existing reinforcing steel is not allowed to be cut per Attachment Notes 1 and 4 on Sheet 48. The existing transverse reinforcing in the box girder bottom slab is #6 bars spaced at 6" centers as shown on the existing plans. Comparing the positions of these bars to the drilled anchor bolt and wiring holes shown in this detail, the requirements of Notes 1 and 4 cannot be met.	B	The existing 2" diameter vent holes on the bottom of the box girder in the REL will be utilized for all wiring needed to power the middle and sides of all straddle bent locations; therefore, the 2" diameter wiring holes that were to be drilled through the box girder bottom are no longer needed. A 5'-0" offset from the Straddle Bent has been shown on sheet no. 43 so that the bars spaced at 6" centers are missed.	

Project Name:

Project No: O-01217
 Department:
 Division:
 Designer: KHA
 Review Type: 100% Submittal
 Description: Selmon Expressway Aesthetic Lighting - Lighting Plans
 Date:



Codes:

- A. Agree w/ comment – will be corrected, added, or clarified.
- D. Disagree w/ comment

- (1) Indicate drawing no./page no. or use "G" for general comment.
- (2) To be filled out by Designer.
- (3) To be determined by THEA.

Item No	Page No ⁽¹⁾	Reviewer	Comment	Code ⁽²⁾	Response ⁽²⁾	Final Disposition ⁽³⁾
			b. If the Structural Arm Type 5 is intended to be transversely centered on the box girder bottom slab, the 4 foot spacing in the transverse direction between the vertical HSS tubes/baseplates places the 2" diameter wiring holes that are to be drilled through the box girder bottom slab directly in conflict with the existing longitudinal #4 bars spaced at 1'-0" centers that are shown on the existing plans. Thus, Notes 1 and 4 referenced above cannot be met. It should be noted that the Structural Arm Type 5 is not actually dimensioned anywhere in the plan set to be centered on the box girder, it is only drawn that way in several locations.	B	The existing 2" diameter vent holes on the bottom of the box girder in the REL will be utilized for all wiring needed to power the middle and sides of all straddle bent locations; therefore, the 2" diameter wiring holes that were to be drilled through the box girder bottom are no longer needed. Also, the structural arm type 5 will be dimensioned in the plan set.	
			3. BASEPLATE DETAIL: Hole diameters for anchor bolts are not shown.	A	Agreed, the dimension will be shown.	
			4. Several weld symbols as shown are not consistent with AWS standard practice. See the Structures Detailing Manual for requirements.	A	Weld symbols will be modified to be consistent with AWS standard practice.	
			5. ABUTMENT, STRADDLE BENT-SIDES, AND RETAINING WALL detail:			
			a. "Straddle Bent-Sides" will have to be deleted from the title of this detail when new structural arm details for use on straddle bent columns are developed.	A	The "Straddle Bent-Sides" title will refer to the same detail.	
			b. "Straddle Bent" will have to be deleted from the callout for the concrete component that the Structural Arm Type 3 or 4 is attached to when new structural arm details for use on straddle bent columns are developed.	B	The "Straddle Bent" on the callout will stay since the detail still refers to the straddle bent.	
			c. Baseplate details are not shown.	A	The baseplate detail title has been modified to reflect baseplate detail locations.	
			d. A plan note requiring pullout tests for the anchor bolts that are in sustained tension is not included.	B	Under-cut anchors will be used therefore pullout tests are not required.	
			e. Installation of adhesive bonded anchors is governed by Specification 416 which contains extensive installation and field testing criteria. After the time delay necessary for the adhesive to cure and reach full strength, per Section 416-6 restrained pullout tests are required to be performed by an independent testing agency followed by the submission of test reports signed and sealed by a Professional Engineer. This process can be time consuming even if all the pullout tests are successful. Section 416-6 goes on to require additional pullout tests for each test failure which adds even more time delays. Considering that historical pullout test failure rates have been as high as 40%, has the use of undercut anchors been considered? Note that per Developmental Specification 416-6.1.2, if the undercut anchors have marked setting indicators and the anchors are properly installed, field pullout testing will not be required.	B	Under-cut anchors will be used therefore pullout tests are not required.	
			f. The structural arm is shown to be rigidly constructed and existing reinforcing steel is not allowed to be cut per Attachment Notes 1 and 4 on Sheet 48. Have the positions of the anchor bolts been compared to the existing vertical and horizontal reinforcing in the MSE wall coping to determine if the requirements of Notes 1 and 4 can be met? Note that when this project was constructed, the reinforcing within MSE wall copings varied between the various MSE retaining wall suppliers.	B	The structural arm detail has been modified to reduce the number of adhesive anchors from eight (8) to four (4); thus, reducing the risk of a conflict with the existing steel reinforcement. Also, slotted holes will be provided to allow tolerance in case of a conflict between the adhesive anchors and the existing reinforcing steel.	
			6. Which holes and horizontal post does Note 4 refer to? Which direction(s) would these slotted holes be oriented?	B	The note is deleted it does not refer to any slotted holes on the structure.	
			7. 1/2" diameter exit holes and holes between welded HSS members for wiring are not shown	A	Correct, the exit holes and holes between welded HSS members will be shown.	

Project Name:

Project No: O-01217

Department:

Division:

Designer: KHA

Review Type: 100% Submittal

Description: Selmon Expressway Aesthetic Lighting - Lighting Plans

Date:



Codes:

A. Agree w/ comment – will be corrected, added, or clarified.

D. Disagree w/ comment

⁽¹⁾ Indicate drawing no./page no. or use "G" for general comment.

⁽²⁾ To be filled out by Designer.

⁽³⁾ To be determined by THEA.

Item No	Page No ⁽¹⁾	Reviewer	Comment	Code ⁽²⁾	Response ⁽²⁾	Final Disposition ⁽³⁾
			8. Additional access holes to facilitate wire pulling around the 90 degree corners are not shown at the welded connections between the HSS members.	A	Agreed, access holes around the 90 degree corners and the welded connections of the HSS members will be shown.	
8	51		The type of concrete anchor required or permitted is not specified.	A	The type of concrete anchor has been specified as undercut anchor system.	
9	53		How will the proposed H-frame be attached to the inside of the segmental box girder?	A	A detail has been added to this sheet to show the attachment of the H-frame to the box girder.	
10	56		1. How will rubber grommets as shown for the wiring exit holes be installed in the wiring holes between the welded HSS members?	A	Thicker grommets can be utilized in locations between welded HSS members and callouts for plastic blanking end caps have been called out in the details where applicable.	
			2. An opening is shown in the top of the right-side vertical post which implies the proposed link system wiring is intended to be installed within the support bracket. However, no such opening or other any other openings are shown in the details on Sheet 49 for this to be possible.	B	The intention is for the outdoor link system to use the structural arm channels as conduit. Using both the updated structural connection details and wiring detail sheets should be sufficient for locating holes in the structural arms for wiring.	
11	69		MOT Typical A does not appear to be applicable to the installation of light support brackets at straddle piers. Please confirm.	B	A note allowing access to the median or opposing travel lane where necessary has been added to the MOT plans, but in most cases a single lane closure is sufficient to access the straddle bent columns.	

Project Name:

Project No: O-01217
 Department:
 Division:
 Designer: KHA
 Review Type: 100% Submittal
 Description: Selmon Expressway Aesthetic Lighting - ITS Plans
 Date:



Codes:

- A. Agree w/ comment – will be corrected, added, or clarified.
- D. Disagree w/ comment

- ⁽¹⁾ Indicate drawing no./page no. or use "G" for general comment.
- ⁽²⁾ To be filled out by Designer.
- ⁽³⁾ To be determined by THEA.

Item No	Page No ⁽¹⁾	Reviewer	Comment	Code ⁽²⁾	Response ⁽²⁾	Final Disposition ⁽³⁾
1	ITS Plan sheets	Johnson	Noticed that pier numbers on plan sheets reflect the original numbering from REL design. Piers were renumbered since and stenciled in the field. Recommend either renumbering with new system which runs west to east or a general note and cross reference table of original numbers to new numbers. This will reduce chance of confusion on new cabinet and splice locations fo contractor.	A	A general note has been added to cross reference original numbering.	
	IT-29		The term "Epoxy Based Anchorage" is not consistent with standardized terms used in SDG 1.6 and Specifications 416 and 937. If adhesive bonded anchors are intended to be used, additional details are required included anchor diameter and embedment length.	A	"Undercut anchorage system" has replaced "epoxy based anchorage." This has been further detailed out within the lighting plans (wiring detail bridge deck conduit runs sheet).	

Project Name:

Project No: O-01217
Department:
Division:
Designer: KHA
Review Type: *100% Submittal*
Description: Selmon Expressway Aesthetic Lighting - LDAR
Date:



Codes:

- A. Agree w/ comment – will be corrected, added, or clarified.
- D. Disagree w/ comment

- ⁽¹⁾ Indicate drawing no./page no. or use "G" for general comment.
- ⁽²⁾ To be filled out by Designer.
- ⁽³⁾ To be determined by THEA.

Item No	Page No ⁽¹⁾	Reviewer	Comment	Code ⁽²⁾	Response ⁽²⁾	Final Disposition ⁽³⁾

Project Name:

Project No: O-01217

Department:

Division:

Designer: KHA

Review Type: 100% Submittal

Description: Selmon Expressway Aesthetic Lighting - Estimate and Specifications

Date:



Codes:

A. Agree w/ comment – will be corrected, added, or clarified.

D. Disagree w/ comment

⁽¹⁾ Indicate drawing no./page no. or use "G" for general comment.

⁽²⁾ To be filled out by Designer.

⁽³⁾ To be determined by THEA.

Item No	Page No ⁽¹⁾	Reviewer	Comment	Code ⁽²⁾	Response ⁽²⁾	Final Disposition ⁽³⁾
1	Modified Special Provisions	D. Hubbard	Include the MSP in the final specifications package. Refer to the FDOT requirements for formatting.	B	The MSP has been removed in its entirety. Please see response to Item No 3.	
2	Modified Special Provisions	D. Hubbard	MSPs are typically approved before they are signed/sealed as part of the specifications package. Has this MSP been approved by THEA already?	B	The MSP has been removed in its entirety. Please see response to Item No 3.	
3	Modified Special Provisions	D. Hubbard	Is the MSP needed? The specification states "Unless otherwise shown in the Plans,..." yet the MSP is being written to direct the contractor to the plan dimensions. It appears that direction is already provided in the original specification language. Direction provided in the plans always supercedes the specifications.	A	Agreed, the MSP has been removed from future submittals. The plans dictate the junction box sizes, which supercedes the standard specifications.	
4	Modified Special Provisions	D. Hubbard	M635-2.3.1.3 Embedded Junction Boxes does not appear to have any modified language, but the unique section numbering is used. Please indicate the language modification or use the original section number.	B	The MSP has been removed in its entirety. Please see response to Item No 3.	
5	12		Prosecution and Progress – Alternative Bidding: This section is out of place numerically and does not appear to be complete. Please review.	A	This section is placed as generated by Specs on the Web. More information will be provided in regards to the base bid and bid alternate process, pending THEA legal review.	

Project Name:

Project No: O-01217

Department:

Division:

Designer: KHA

Review Type: 100% Submittal

Description: Selmon Expressway Aesthetic Lighting - Design Documentation Report

Date:



Codes:

- A. Agree w/ comment – will be corrected, added, or clarified.
- D. Disagree w/ comment

- ⁽¹⁾ Indicate drawing no./page no. or use "G" for general comment.
- ⁽²⁾ To be filled out by Designer.
- ⁽³⁾ To be determined by THEA.

Item No	Page No ⁽¹⁾	Reviewer	Comment	Code ⁽²⁾	Response ⁽²⁾	Final Disposition ⁽³⁾

Project Name:

Project No: O-01217

Department:

Division:

Designer: KHA

Review Type: 100% Submittal

Description: Selmon Expressway Aesthetic Lighting - Structural Model

Date: 2/17/2020



Codes:

A. Agree w/ comment – will be corrected, added, or clarified.

D. Disagree w/ comment

(1) Indicate drawing no./page no. or use "G" for general comment.

(2) To be filled out by Designer.

(3) To be determined by THEA.

Item No	Page No ⁽¹⁾	Reviewer	Comment	Code ⁽²⁾	Response ⁽²⁾	Final Disposition ⁽³⁾
1		Julian Gutierrez	In the computer model, the horizontal member over the pier cap is pinned as a support. However, only the all tread bar provides continuity between the two structural arms. Please verify that adequate structural stiffness is provided by the all thread bar.	A	Adequate structural stiffness has been provided by the all thread bar.	
2		Julian Gutierrez	The horizontal members over the pier caps will be open to the elements. Please verify that the members will be able to drain via weep holes. This is of special concern at down spout locations and for condensation.	B	The horizontal member has a 2" gap opening; therefore, we do not foresee water intrusion thru this opening.	
3		Julian Gutierrez	Would a locking nut be need for the top threaded rod?	A	Yes, locking nut will be added.	
4		Julian Gutierrez	Pier Plan View: Is the Threaded Rod the same thing as the Reinforcing Bar described in Notes 4 and 5?	A	Yes, the note has been modified to reflect top threaded rod.	
5		Julian Gutierrez	Side Elevation View Section B-B: 1. The callout for the Structural Arm Type 2 is pointing the lower arm of the Structural Arm Type 1.	A	Agreed, the arm has been updated to reflect the correct type.	
			2. Type of weld for the side connection of the horizontal and vertical members of the Structural Arm Type 1 is incorrect for two members of the same size.	A	Correct, the weld has been changed to a flare-bevel groove.	
			3. Is the Threaded Rod the same thing as the Reinforcing Bar described in Notes 4 and 5?	A	Yes, the note has been modified to reflect top threaded rod.	
6		Julian Gutierrez	Detail A: 1. Dimensions for the foot that is welded to the threaded rod are not shown.	A	Agreed, the dimension will be added.	
			2. Weld type, size and location are not shown.	A	Agreed, the weld will be added.	
7		Julian Gutierrez	Detail B: Is the Threaded Rod the same thing as the Reinforcing Bar described in Notes 4 and 5?	A	Yes, the note has been modified to reflect top threaded rod.	
8		Julian Gutierrez	Note 2: Holes for wiring should be shown on this drawing to facilitate preparation of the shop drawings. Note that there are no structural related shop drawing submittal requirements listed in the Structural General Notes or on the Key Sheet.	A	Agreed, holes will be shown and a note will be added to request shop drawing submittal requirements.	
9		Julian Gutierrez	Note 4: Wingnuts are called for but none are shown on the drawing.	A	Wingnuts will be shown.	
10		Julian Gutierrez	Note 5: How will the required 3000 lb force be obtained and measured?	A	A note will be added to follow Designation FM 5-581 for performing rotational capacity test to ensure the fastener assemblies are capable of developing the specified bolt tension.	

Project Name:

Project No: O-01217

Department:

Division:

Designer: KHA

Review Type: 100% Submittal

Description: Selmon Expressway Aesthetic Lighting - Lighting Plans

Date:



Codes:

A. Agree w/ comment – will be corrected, added, or clarified.

D. Disagree w/ comment

(1) Indicate drawing no./page no. or use "G" for general comment.

(2) To be filled out by Designer.

(3) To be determined by THEA.

Item No	Page No ⁽¹⁾	Reviewer	Comment	Code ⁽²⁾	Response ⁽²⁾	Final Disposition ⁽³⁾
1	42		The vertical location of the Structural Arm Type 3 on the pier columns is not shown.	B	The vertical location of Structural Arm Type 3 on the straddle bent column is shown in the side view on sheet 43.	Comment closed
2	43		1. Structural Arm Type 5 Side View: The 3 foot length of the vertical member is dimensioned to the top of the bottom slab (inside) of the box girder, not the bottom (outside) of the box girder. Please confirm.	A	Confirmed. This provides roughly 2'- 2 1/2" of space between the bottom (outside) and horizontal member of the structural arm Type 5.	Comment closed
			2. Has the remaining vertical clearance beneath the proposed structural arm been confirmed to meet current the 17.5' clearance requirement per FDM 210.10.3 at all planned installation locations?	A	Agreed, a vertical clearance report has been added to the design doc report.	Comment closed
3	44		1. Why is a table of variables used for dimensions AA, DD and EE if these dimensions do not vary between Abutments 1, 123 and 124?	A	Agreed, the table of variables has been updated to remove dimension AA, but keep DD and EE to show when the luminaires are not present on certain abutments. Bid alternate plans have been checked with the same intention.	Comment closed
			2. What is the difference between a "Structural Arm Type 3" shown on this sheet and a "Structural Arm Type 4" shown on Sheet 45?	B	Structural arm Type 3 utilizes mounting plate type 2 as indicated in the plans, whereas Structural arm Type 4 utilizes mounting plate type 1. Please see Structural Arm Detail Luminaire Mounting Plate for more information.	Recommend labeling the mounting plates accordingly on Sheet 51 to clarify this.
4	45		Structural Arm Type 4 Side View:			
			1. Mounting the baseplate level with the bottom of the traffic railing results in less than 1" of concrete between the top edge of the uppermost drilled holes and the top of the concrete coping. This small amount of concrete will likely spall as the holes are drilled.	A	Agreed, the base plate has been shifted downward to avoid potential spalling. Please see updated dimension.	Okay at top, however now that the assembly has been shifted downwards, the 7 1/2" embedment of the lowermost anchor bolts exceeds the 4" thickness of the lower part of the MSE wall coping. Please balance the adjustment.
			2. The structural arm is shown to be rigidly constructed on Sheet 50 and existing reinforcing steel is not allowed to be cut per Attachment Notes 1 and 4 on Sheet 48. Have the positions of the anchor bolts been compared to the existing vertical and horizontal reinforcing in the MSE wall coping to determine if the requirements of Notes 1 and 4 can be met? Note that when this project was constructed, the reinforcing within MSE wall copings varied between the various retaining wall suppliers.	A	The structural arm detail on sheet 50 has been modified to reduce the number of adhesive anchors from eight (8) to four (4); thus, reducing the risk of a conflict with the existing steel reinforcement. Also, slotted holes will be provided to allow tolerance in case of a conflict between the adhesive anchors and the existing reinforcing steel.	Comment closed
5	48		1. Materials Note 2: ASTM A709 does not contain criteria for Grade 60 steel.	A	Correct, the grade is 36 per SDG 5.3.1.A.	Comment closed
			2. Fabrication Note 1.A: The bolt diameter is required to be bolt hole diameter plus 3/4". Please confirm. If this is intended to be the anchor bolt hole diameter in the baseplates and post clamps, it conflicts with the slotted holes called for on Sheet 49. If it is intended to be the drilled hole diameter in the concrete member, it conflicts with the requirements of SDG 1.6.1.C and Note 3 on Sheets 49 and 50.	A	The bolt hole diameter has been changed to bolt hole diameter plus 1/16".	Note 1A now calls for the bolts to be bolt hole diameter plus 1/16" prior to galvanizing. Thus, the bolts won't fit into the holes.
			3. Structure Erection – General Requirements: These three notes appear to be geared towards construction of a bridge, not installation of relatively small and lightweight luminaire support brackets.	A	Agreed. Notes will be modified to be geared towards the erection of a relatively small and lightweight luminaire support brackets.	Comment closed
			4. General Architectural Project Note 1: The last sentence conflicts with FDOT standard practice.	A	Correct, the sentence has been removed.	Comment closed

The plate size height has been changed to 6" to allow the revised 4" embedment of the undercut anchors.

Agreed. Note corrected to reflect galvanization increase.

Project Name:

Project No: O-01217

Department:

Division:

Designer: KHA

Review Type: 100% Submittal

Description: Selmon Expressway Aesthetic Lighting - Lighting Plans

Date:



Codes:

A. Agree w/ comment – will be corrected, added, or clarified.

D. Disagree w/ comment

The intention is for sheet 57 to serve as a go-by for wiring through the structural arms. Between the structural connection details depicting hole locations and the wiring/hardware shown on sheet 57, the contractor has the needed information to wire all other structural arms not on the piers.

Item No	Page No ⁽¹⁾	Reviewer	Comment	Code ⁽²⁾	Response ⁽²⁾	Final Disposition ⁽³⁾
6	49		1. Detail 1: Labeling of Structural Arm Type 2 conflicts with that shown on Sheet 41.	A	Correct, the labeling of arm types will match page 41.	Comment closed
			2. Note 2: What hole is this note referring to?	A	Note 1 has been reworded to reference the wiring schematic. Hole locations have been updated on the sheet.	Sheet 64 does not include sufficient details for wiring holes when compared to similar details shown on Sheet 57 for the structural arm at piers.
			3. Note 4: Center to center dimension between the Structural Arms Type 1 is not shown on the Structural Arm Detail Pier sheet.	A	Agreed, the dimension will be shown.	Comment closed
			4. Note 5: No holes are shown on the horizontal posts in Section A-A. Which holes should this note refer to? Which direction(s) would these slotted holes be oriented?	A	Agreed, Note 3 has been reworded to clarify slotted hole placement.	Comment closed
			5. A plan note requiring pullout tests for the anchor bolts that are in sustained tension is not included.	B	Epoxy anchors in sustained tension will be replaced with undercut anchors; therefore, pullout tests will no longer be required.	Comment closed
			6. Horizontal position of the centermost 3/4" plate is not shown in Section A-A.	A	Agreed, the dimension will be shown.	Comment closed
			7. The thickness of the Post Clamp is not shown. Is the Post Clamp intended to be a single bent plate or fabricated from multiple smaller plates? For a single bent plate, has the inside bending radius at the corners been compared to the shape of the HSS?	A	Agreed, the dimension will be shown. The post clamp is intended to be a single plate. The radius for the post clamp will match the HSS radius.	Comment closed
			8. References to "Pier" will have to be deleted from this sheet when new structural arm details for use on pier columns are developed.	A	Agreed, the references will be deleted.	Comment closed
			9. 1 1/2" diameter exit holes and holes between welded HSS members for wiring are not shown. Note that some exit holes are shown on Sheet 56 but the holes between welded HSS members are not.	A	Correct, the exit holes and holes between welded HSS members will be shown.	See comment 6 - 2 above
			10. Additional access holes to facilitate wire pulling around the 90 degree corners are not shown at the welded connections between the HSS members.	A	Correct, the exit holes and holes between welded HSS members will be shown.	See comment 6 - 2 above
			11. The structural arm is shown to be rigidly constructed and existing reinforcing steel is not allowed to be cut per Attachment Notes 1 and 4 on Sheet 48. Given this combination, how can the arm be shifted to comply with Notes 1 and 4 if reinforcing steel is only encountered when drilling an anchor bolt hole at one location?	A	Slotted holes have been provided at both vertical post clamps to be able to shift anchors to avoid existing steel reinforcement.	Comment closed
7	50		1. Straddle Bent Middle (Elevation View):			
			a. The bolts are labeled as adhesive bonded anchors but are shown as through bolts.	A	Agreed, bolts are thru-bolts.	Comment closed
			b. Recommend requiring the use of lock washers or self-locking nuts to reduce the potential for the connections to loosen due to traffic and wind induced vibrations.	A	Agreed, self-locking nuts will be used on the straddle bent middle.	Comment closed
			c. The diameter of the anchor bolt holes that are to be drilled in the box girder bottom slab is not shown.	A	Agreed, the dimension will be shown.	Comment closed
			d. The overall height of the assembly is not shown.	B	The overall height of the assembly is shown on sheet 43.	Comment closed
			2. Straddle Bent Middle (Plan View):			
			a. The structural arm is shown to be rigidly constructed and existing reinforcing steel is not allowed to be cut per Attachment Notes 1 and 4 on Sheet 48. The existing transverse reinforcing in the box girder bottom slab is #6 bars spaced at 6" centers as shown on the existing plans. Comparing the positions of these bars to the drilled anchor bolt and wiring holes shown in this detail, the requirements of Notes 1 and 4 cannot be met.	B	The existing 2" diameter vent holes on the bottom of the box girder in the REL will be utilized for all wiring needed to power the middle and sides of all straddle bent locations; therefore, the 2" diameter wiring holes that were to be drilled through the box girder bottom are no longer needed. A 5'-0" offset from the Straddle Bent has been shown on sheet no. 43 so that the bars spaced at 6" centers are missed.	Comment closed

a. "15/16" Ø Holes (Typ.)" are for the bolt holes not the slotted holes. Rephrased to say "15/16" Ø bolt Hole (Typ.).
 b. Agreed dimensions will be shown.
 c. Baseplates are orientated with their long sides facing longitudinally to the bridge. Slotted holes are placed for thru bolts to avoid transverse 6" spaced rebar in the segment.

Project Name:
 Project No: O-01217
 Department:
 Division:
 Designer: KHA
 Review Type: 100% Submittal
 Description: Selmon Expressway Aesthetic Lighting - Lighting Plans
 Date:

AUTHORITY

w/ comment – will be corrected, added, or clarified.
 ee w/ comment

(1) Indicate drawing no./page no. or use "G" for general comment.
 (2) To be filled out by Designer.
 (3) To be determined by THEA.

Item No	Page No (1)	Reviewer	Comment	Code (2)	Response (2)	Final Disposition (3)
			b. If the Structural Arm Type 5 is intended to be transversely centered on the box girder bottom slab, the 4 foot spacing in the transverse direction between the vertical HSS tubes/baseplates places the 2" diameter wiring holes that are to be drilled through the box girder bottom slab directly in conflict with the existing longitudinal #4 bars spaced at 1'-0" centers that are shown on the existing plans. Thus, Notes 1 and 4 referenced above cannot be met. It should be noted that the Structural Arm Type 5 is not actually dimensioned anywhere in the plan set to be centered on the box girder, it is only drawn that way in several locations.	B	The existing 2" diameter vent holes on the bottom of the box girder in the REL will be utilized for all wiring needed to power the middle and sides of all straddle bent locations; therefore, the 2" diameter wiring holes that were to be drilled through the box girder bottom are no longer needed. Also, the structural arm type 5 will be dimensioned in the plan set.	Comment closed
			3. BASEPLATE DETAIL: Hole diameters for anchor bolts are not shown.	A	Agreed, the dimension will be shown.	
			4. Several weld symbols as shown are not consistent with AWS standard practice. See the Structures Detailing Manual for requirements.	A	Weld symbols will be modified to be consistent with AWS standard practice.	Comment closed
			5. ABUTMENT, STRADDLE BENT-SIDES, AND RETAINING WALL detail:			
			a. "Straddle Bent-Sides" will have to be deleted from the title of this detail when new structural arm details for use on straddle bent columns are developed.	A	The "Straddle Bent-Sides" title will refer to the same detail.	Using the base plate dimensions shown, the 10 1/2" distance from the top of the pier column to the top of the HSS shown on Sheet 43 and assuming 3" of cover to the topmost stirrup shown on existing plans sheet T-174, the lowermost anchor bolts will conflict with a stirrup. Please confirm vertical position of structural arm and adjust the 10 1/2" dimension shown on Sheet 43 as required.
			b. "Straddle Bent" will have to be deleted from the callout for the concrete component that the Structural Arm Type 3 or 4 is attached to when new structural arm details for use on straddle bent columns are developed.	B	The "Straddle Bent" on the callout will stay since the detail still refers to the straddle bent.	
			c. Baseplate details are not shown.	A	The baseplate detail title has been modified to reflect baseplate detail locations.	Comment closed
			d. A plan note requiring pullout tests for the anchor bolts that are in sustained tension is not included.	B	Under-cut anchors will be used therefore pullout tests are not required.	For d. & e.: Response accepted, but anchor bolt diameter and embedment shown are not consistent with those of Hilti HDA-R undercut anchors.
			e. Installation of adhesive bonded anchors is governed by Specification 416 which contains extensive installation and field testing criteria. After the time delay necessary for the adhesive to cure and reach full strength, per Section 416-6 restrained pullout tests are required to be performed by an independent testing agency followed by the submission of test reports signed and sealed by a Professional Engineer. This process can be time consuming even if all the pullout tests are successful. Section 416-6 goes on to require additional pullout tests for each test failure which adds even more time delays. Considering that historical pullout test failure rates have been as high as 40%, has the use of undercut anchors been considered? Note that per Developmental Specification 416-6.1.2, if the undercut anchors have marked setting indicators and the anchors are properly installed, field pullout testing will not be required.	B	Under-cut anchors will be used therefore pullout tests are not required. Agreed. The arm has been changed to 9". The constructor has the liberty to position the arm around our given position to avoid rebar when drilling.	Agree. Plans are to be updated along with Hilti runs.
			f. The structural arm is shown to be rigidly constructed and existing reinforcing steel is not allowed to be cut per Attachment Notes 1 and 4 on Sheet 48. Have the positions of the anchor bolts been compared to the existing vertical and horizontal reinforcing in the MSE wall coping to determine if the requirements of Notes 1 and 4 can be met? Note that when this project was constructed, the reinforcing within MSE wall copings varied between the various MSE retaining wall suppliers.	B	The structural arm detail has been modified to reduce the number of adhesive anchors from eight (8) to four (4); thus, reducing the risk of a conflict with the existing steel reinforcement. Also, slotted holes will be provided to allow tolerance in case of a conflict between the adhesive anchors and the existing reinforcing steel.	Comment closed
			6. Which holes and horizontal post does Note 4 refer to? Which direction(s) would these slotted holes be oriented?	B	The note is deleted it does not refer to any slotted holes on the structure.	Comment closed
			7. 1 1/2" diameter exit holes and holes between welded HSS members for wiring are not shown.	A	Correct, the exit holes and holes between welded HSS members will be shown.	Comment closed

Straddle Bent Middle Baseplate detail:
 a. Bolt holes are double labeled as "1" x 1 1/2" Slotted Holes (Typ.)" and "15/16" Ø Holes (Typ.).
 b. Locations of the bolt holes are not dimensioned in the transverse direction.
 c. Orientation of the base plates relative to the bridge or structural arm is not shown. Based on how the base plate is shown in the Straddle Bent Middle Elevation Front View, the long side of the base plate would be transverse to the bridge. Comparing the positions of the slotted holes to the reinforcing shown in the existing bridge plans, the slotted holes are not needed in this direction. If the base plates are intended to be oriented with their long sides oriented longitudinally to the bridge, the ends of the base plates touch and at least one slotted anchor bolt hole conflicts with an existing reinforcing bar shown in the existing bridge plans. Please clarify orientation of base plates and confirm that there are not conflicts with the existing reinforcing bars in the bottom slab of the box girder.

Project Name:
 Project No: O-01217
 Department:
 Division:
 Designer: KHA
 Review Type: 100% Submittal
 Description: Selmon Expressway Aesthetic Lighting - Lighting Plans
 Date:



Codes:
A. Agree w/ comment – will be corrected, added, or clarified.
D. Disagree w/ comment

(1) Indicate drawing no./page no. or use "G" for general comment.
 (2) To be filled out by Designer.
 (3) To be determined by THEA.

Agree. Plans are to be updated along with Hilti runs.

Item No	Page No ⁽¹⁾	Reviewer	Comment	Code ⁽²⁾	Response ⁽²⁾	Final Disposition ⁽³⁾
			8. Additional access holes to facilitate wire pulling around the 90 degree corners are not shown at the welded connections between the HSS members.	A	Agreed, access holes around the 90 degree corners and the welded connections of the HSS members will be shown.	Comment closed
8	51		The type of concrete anchor required or permitted is not specified.	A	The type of concrete anchor has been specified as undercut anchor system.	Anchor bolt diameter & embedment shown are not consistent with those of HDA-R undercut anchors.
9	53		How will the proposed H-frame be attached to the inside of the segmental box girder?	A	A detail has been added to this sheet to show the attachment of the H-frame to the box girder.	
10	56		1. How will rubber grommets as shown for the wiring exit holes be installed in the wiring holes between the welded HSS members?	A	Thicker grommets can be utilized in locations between welded HSS members and callouts for plastic blanking end caps have been called out in the details where applicable.	Comment closed
			2. An opening is shown in the top of the right-side vertical post which implies the proposed link system wiring is intended to be installed within the support bracket. However, no such opening or other any other openings are shown in the details on Sheet 49 for this to be possible.	B	The intention is for the outdoor link system to use the structural arm channels as conduit. Using both the updated structural connection details and wiring detail sheets should be sufficient for locating holes in the structural arms for wiring.	Comment closed
11	69		MOT Typical A does not appear to be applicable to the installation of light support brackets at straddle piers. Please confirm.	B	A note allowing access to the median or opposing travel lane where necessary has been added to the MOT plans, but in most cases a single lane closure is sufficient to access the straddle bent columns.	Comment closed

Item 9. Embedment of the 5/8" x 5" undercut anchor is not shown. If the same detail is planned for use at the top of the H-frame, and depending on the required embedment depth of the anchors, has the potential for conflicts with the top slab transverse PT tendons been investigated?

The connection is through the bottom slab and the top. Additional details have been shown to reflect this. Please see note 3 on this sheet that provides flexibility in h-frame location to avoid traverse PT tendons. There is sufficient space between these tendons for the H-frame vertical members to fit between, after non-destructive testing.

Project Name:

Project No: O-01217
 Department:
 Division:
 Designer: KHA
 Review Type: 100% Submittal
 Description: Selmon Expressway Aesthetic Lighting - ITS Plans
 Date:



Codes:

- A. Agree w/ comment – will be corrected, added, or clarified.
- D. Disagree w/ comment

- ⁽¹⁾ Indicate drawing no./page no. or use "G" for general comment.
- ⁽²⁾ To be filled out by Designer.
- ⁽³⁾ To be determined by THEA.

Item No	Page No ⁽¹⁾	Reviewer	Comment	Code ⁽²⁾	Response ⁽²⁾	Final Disposition ⁽³⁾
1	ITS Plan sheets	Johnson	Noticed that pier numbers on plan sheets reflect the original numbering from REL design. Piers were renumbered since and stenciled in the field. Recommend either renumbering with new system which runs west to east or a general note and cross reference table of original numbers to new numbers. This will reduce chance of confusion on new cabinet and splice locations fo contractor.	A	A general note has been added to cross reference original numbering.	
	IT-29		The term "Epoxy Based Anchorage" is not consistent with standardized terms used in SDG 1.6 and Specifications 416 and 937. If adhesive bonded anchors are intended to be used, additional details are required included anchor diameter and embedment length.	A	"Undercut anchorage system" has replaced "epoxy based anchorage." This has been further detailed out within the lighting plans (wiring detail bridge deck conduit runs sheet).	

Project Name:

Project No: O-01217
Department:
Division:
Designer: KHA
Review Type: 100% Submittal
Description: Selmon Expressway Aesthetic Lighting - LDAR
Date:



Codes:

- A. Agree w/ comment – will be corrected, added, or clarified.
- D. Disagree w/ comment

- ⁽¹⁾ Indicate drawing no./page no. or use "G" for general comment.
- ⁽²⁾ To be filled out by Designer.
- ⁽³⁾ To be determined by THEA.

Item No	Page No ⁽¹⁾	Reviewer	Comment	Code ⁽²⁾	Response ⁽²⁾	Final Disposition ⁽³⁾

Project Name:

Project No: O-01217

Department:

Division:

Designer: KHA

Review Type: 100% Submittal

Description: Selmon Expressway Aesthetic Lighting - Estimate and Specifications

Date:



Codes:

A. Agree w/ comment – will be corrected, added, or clarified.

D. Disagree w/ comment

⁽¹⁾ Indicate drawing no./page no. or use "G" for general comment.

⁽²⁾ To be filled out by Designer.

⁽³⁾ To be determined by THEA.

Item No	Page No ⁽¹⁾	Reviewer	Comment	Code ⁽²⁾	Response ⁽²⁾	Final Disposition ⁽³⁾
1	Modified Special Provisions	D. Hubbard	Include the MSP in the final specifications package. Refer to the FDOT requirements for formatting.	B	The MSP has been removed in its entirety. Please see response to Item No 3.	
2	Modified Special Provisions	D. Hubbard	MSPs are typically approved before they are signed/sealed as part of the specifications package. Has this MSP been approved by THEA already?	B	The MSP has been removed in its entirety. Please see response to Item No 3.	
3	Modified Special Provisions	D. Hubbard	Is the MSP needed? The specification states "Unless otherwise shown in the Plans,..." yet the MSP is being written to direct the contractor to the plan dimensions. It appears that direction is already provided in the original specification language. Direction provided in the plans always supercedes the specifications.	A	Agreed, the MSP has been removed from future submittals. The plans dictate the junction box sizes, which supercedes the standard specifications.	
4	Modified Special Provisions	D. Hubbard	M635-2.3.1.3 Embedded Junction Boxes does not appear to have any modified language, but the unique section numbering is used. Please indicate the language modification or use the original section number.	B	The MSP has been removed in its entirety. Please see response to Item No 3.	
5	12		Prosecution and Progress – Alternative Bidding: This section is out of place numerically and does not appear to be complete. Please review.	A	This section is placed as generated by Specs on the Web. More information will be provided in regards to the base bid and bid alternate process, pending THEA legal review.	

Project Name:

Project No: O-01217
Department:
Division:
Designer: KHA
Review Type: 100% Submittal
Description: Selmon Expressway Aesthetic Lighting - Design Documentation Report
Date:



Codes:

- A. Agree w/ comment – will be corrected, added, or clarified.
- D. Disagree w/ comment

- ⁽¹⁾ Indicate drawing no./page no. or use "G" for general comment.
- ⁽²⁾ To be filled out by Designer.
- ⁽³⁾ To be determined by THEA.

Item No	Page No ⁽¹⁾	Reviewer	Comment	Code ⁽²⁾	Response ⁽²⁾	Final Disposition ⁽³⁾

Project Name:

Project No: O-01217
Department:
Division:
Designer: KHA
Review Type: 100% Resubmittal
Description: Selmon Expressway Aesthetic Lighting - ITS Plans
Date:



Codes:

- A. Agree w/ comment – will be corrected, added, or clarified.
- D. Disagree w/ comment

- ⁽¹⁾ Indicate drawing no./page no. or use "G" for general comment.
- ⁽²⁾ To be filled out by Designer.
- ⁽³⁾ To be determined by THEA.

Item No	Page No ⁽¹⁾	Reviewer	Comment	Code ⁽²⁾	Response ⁽²⁾	Final Disposition ⁽³⁾

Project Name:

Project No: O-01217
Department:
Division:
Designer: KHA
Review Type: 100% Resubmittal
Description: Selmon Expressway Aesthetic Lighting - LDAR
Date:



Codes:

- A. Agree w/ comment – will be corrected, added, or clarified.
- D. Disagree w/ comment

- ⁽¹⁾ Indicate drawing no./page no. or use "G" for general comment.
- ⁽²⁾ To be filled out by Designer.
- ⁽³⁾ To be determined by THEA.

Item No	Page No ⁽¹⁾	Reviewer	Comment	Code ⁽²⁾	Response ⁽²⁾	Final Disposition ⁽³⁾

Project Name:

Project No: O-01217

Department:

Division:

Designer: KHA

Review Type: 100% Resubmittal

Description: Selmon Expressway Aesthetic Lighting - Estimate and Specifications

Date:



Codes:

A. Agree w/ comment – will be corrected, added, or clarified.

D. Disagree w/ comment

⁽¹⁾ Indicate drawing no./page no. or use "G" for general comment.

⁽²⁾ To be filled out by Designer.

⁽³⁾ To be determined by THEA.

Item No	Page No ⁽¹⁾	Reviewer	Comment	Code ⁽²⁾	Response ⁽²⁾	Final Disposition ⁽³⁾
1	Specifications Page 5	D. Hubbard	The specifications indicate there is no utility work anticipated by other agencies, however there are pay items indicating assemblies being provided by TECO in the lighting plans. Please clarify and confirm that in fact no work is being performed by utility companies.	D	This section of the specifications pertains to UAO's with no utility work schedules. TECO is not required to provide a UWS for meter furnishing, thus this section still applied to all other facilities on the project.	
2	Specifications Page 14	D. Hubbard	Clarify the intent of "In Evaluating Bids, Owner will consider..Notice of Award." This sentence appears unnecessary, and in the event the contract documents are not complete at time of bid THEA is not offered any protection against claims as a result of bidding on an incomplete set of plans. As written, the specification suggests the Owner is considering whether or not the Bids are complete, not whether or not the contract documents themselves are complete. GEC team recommends deleting the language and substituting with the following, " <i>Evaluation of Bids:</i> <i>Determination of the successful bidder for the contract will be based on the total sum of the "Base Bid" and "Bid Alternate" prices. Based on available funding at the time of award, the Authority in its sole discretion shall determine if the "Bid Alternate" work will be included with the contract ."</i>	A	This language has been added into the specifications package as requested and agreed upon by THEA.	

Project Name:

Project No: O-01217

Department:

Division:

Designer: KHA

Review Type: 100% Resubmittal

Description: Selmon Expressway Aesthetic Lighting - Design Documentation Report

Date:



Codes:

- A. Agree w/ comment – will be corrected, added, or clarified.
- D. Disagree w/ comment

- ⁽¹⁾ Indicate drawing no./page no. or use "G" for general comment.
- ⁽²⁾ To be filled out by Designer.
- ⁽³⁾ To be determined by THEA.

Item No	Page No ⁽¹⁾	Reviewer	Comment	Code ⁽²⁾	Response ⁽²⁾	Final Disposition ⁽³⁾

Rehm, Jacob

From: Rios, Ivonne
Sent: Monday, March 9, 2020 2:20 PM
To: Leep, Jordan
Cc: Perez, Jorge; Rehm, Jacob
Subject: RE: REL Lighting Revised 100% Plans
Attachments: 2020.03.09_148872000 THEA StructuresSet.pdf

Jordan and Jacob,

Here are the responses and changes we made to the plans to comply with the comments from THEA:

Plan Sheet	Review Type	Comments and Responses
Sheet 48	100% Resubmittal Item No. 3, Comments 2 and 3	<p>2. Materials: 5. Anchor Bolts, Nuts and Washers: Grades of bolts and washers are not consistent with those for Hilti HDA-R Undercut Anchors.</p> <p>Response: Grades will be updated for consistency. Final Disposition: Was not corrected.</p> <p><u>Response:</u> Materials note 5 has been changed to reflect HDA-R stainless steel Type 316 grade with a minimum Fy= 92.8 ksi and Fu= 116 ksi. Nuts and washers of this system also show Type 316 grade accordingly.</p> <p>3. Fabrication: 2. Coating: Note A: Hilti HDA-R Undercut Anchors are made of stainless steel which does not get galvanized.</p> <p>Response: Agree. Final Disposition: Was not corrected.</p> <p>New comment on Fabrication: 2. Coating: Note a: in the latest submittal: CIP anchor rods are not used for this project.</p> <p><u>Response:</u> The undercut anchors, nuts, and washers that pertain to this system cannot be galvanized because they are stainless steel. This note has been changed to exclude the undercut anchors and its components.</p> <p><u>New comment/Response:</u> "CIP anchors" has been removed from the note</p>

	<p>100% Resubmittal Item No. 11</p>	<p>11. Structure Erection-General Requirements, Note 2: How will the required 3000 lb force be obtained and measured?</p> <p>Response: A note has already been added to follow Designation FM 5-581 for performing rotational capacity test to ensure the fastener assemblies are capable of developing the specified bolt tension.</p> <p>Final Disposition: FM 5-581 covers the procedure for performing Rotational Capacity tests on bolts using a Tension Calibrator to ensure that fastener assemblies are capable of developing the specified bolt tension. It is not a test used in the field to determine the tension in a bolt during installation or for inspection purposes. Even if it were, the flexibility of the Structural Arm Type 1A and 2 assembly will distort the test results.</p> <p><u>Response:</u> Note 2 has been modified to reflect testing method "Skidmore-Wilhelm bolt tension calibrator" to measure tension in the bolt during installation or inspection purposes.</p>
--	-------------------------------------	--

Best regards,

Ivonne E. Rios Medri, E.I

Structural Engineer In Training

Kimley-Horn | 189 S. Orange Avenue, Suite 1000, Orlando, FL 32801

Direct: 407-459-8088 | Kimley-Horn.com

Connect with us: [Twitter](#) | [LinkedIn](#) | [Facebook](#) | [Instagram](#)

Celebrating 12 years as one of FORTUNE's 100 Best Companies to Work For

From: Perez, Jorge

Sent: Friday, March 6, 2020 3:32 PM

To: Rios, Ivonne <Ivonne.Rios@kimley-horn.com>

Subject: FW: REL Lighting Revised 100% Plans

Importance: High

Ivonne,

I am waiting to hear back from Dwight regarding comment 11 below. I will keep you posted. Have a great day.

Jorge L. Perez, P.E. | Senior Project Manager - Structures

Kimley-Horn | 189 South Orange Avenue, Suite 1000, Orlando, FL 32801

Direct: 407-427-1640 | Mobile: 813-507-4293 | Main: 407-898-1511

Connect with us: [Twitter](#) | [LinkedIn](#) | [Facebook](#) | [Instagram](#)

APPENDIX D: VOLTAGE DROP CALCULATIONS

Voltage Drop Calculation Summary

The calculations within this section summarize the voltage requirements and loads on eleven proposed load centers within this project (AA-KK). Each load center provides 240/480V, single phase, circuitry to the proposed lighting system. In order to satisfy a 5% maximum voltage drop, a complete circuit analysis was performed for each load center/circuit. The Acclaim Outdoor Link System™ was utilized within the junction boxes on the piers, straddle bents, and abutments to assure a secure electrical connection that provides ease of constructability for future luminaires. The retaining walls take a different approach, using “daisy-chains” to splice from mainline DMX and AC electrical runs (See Luminaire Cut Sheets). The overall voltage drop for each circuit must consider the voltage drop from the Outdoor Link System™ of the highest voltage-demanding luminaire configuration within each structure. The last five pages identify these worst-case scenarios and provide an additive voltage drop figure that should provide a cumulative voltage drop value of 5% or less with the main line circuit calculations. After analyzing each circuit, there are no circuits that exceed the 5% maximum requirement.

Client: THEA
 Project: THEA Aesthetic Lighting

Load Center: KK - STA. 373+98.67
 Conductor Type: THWN COPPER
 Circuit Type: 480/240 VAC, 2 PHASE, 3 WIRE + GROUND
 Direction: EB - GROUND
 Maximum Voltage Drop: 5%
 Minimum Fault Current Ratio: 5:1

CKT #	Phase	Load Amps	BRKR Amps
7	A	13.5	20
7	B	12.5	20

PHASE-TO-NEUTRAL VOLTAGE =	240
CONDUCTOR SIZE =	2
GROUND SIZE =	2
CALCULATED % VOLTAGE DROP =	3.6
CALCULATED FAULT CURRENT RATIO =	15.6

Load #	Phase	Load Description	Load (VA)	Load (amps)	Dist.-Previous load (feet)	Segment Load	Segment Dist. (ft)	Actual Voltage	Total Run Dist. (ft)	Fault Current	Fault Cur. Ratio
1	A	RW1 S	250	1.042	1416.0	13.542	1416.0	232.7	1416	446.0	22.3
2	B		250	1.042	19.0	12.500	1435.0	233.2	1435	440.1	22.0
3	A		250	1.042	19.0	12.500	38.0	232.5	1454	434.4	21.7
4	B		250	1.042	19.0	11.458	38.0	233.0	1473	428.8	21.4
5	A		250	1.042	19.0	11.458	38.0	232.4	1492	423.3	21.2
6	B		250	1.042	19.0	10.417	38.0	232.9	1511	418.0	20.9
7	A		250	1.042	19.0	10.417	38.0	232.2	1530	412.8	20.6
8	B		250	1.042	19.0	9.375	38.0	232.7	1549	407.7	20.4
9	A		250	1.042	19.0	9.375	38.0	232.1	1568	402.8	20.1
10	B		250	1.042	19.0	8.333	38.0	232.6	1587	398.0	19.9
11	A		250	1.042	19.0	8.333	38.0	232.0	1606	393.3	19.7
12	B		250	1.042	19.0	7.292	38.0	232.5	1625	388.7	19.4
13	A		250	1.042	19.0	7.292	38.0	231.9	1644	384.2	19.2
14	B		250	1.042	19.0	6.250	38.0	232.4	1663	379.8	19.0
15	A		250	1.042	19.0	6.250	38.0	231.8	1682	375.5	18.8
16	B		250	1.042	19.0	5.208	38.0	232.3	1701	371.3	18.6
17	A		250	1.042	19.0	5.208	38.0	231.7	1720	367.2	18.4
18	B		250	1.042	19.0	4.167	38.0	232.3	1739	363.2	18.2
19	A		250	1.042	19.0	4.167	38.0	231.6	1758	359.3	18.0
20	B		250	1.042	19.0	3.125	38.0	232.2	1777	355.4	17.8
21	A		250	1.042	19.0	3.125	38.0	231.6	1796	351.7	17.6
22	B		250	1.042	19.0	2.083	38.0	232.2	1815	348.0	17.4
23	A		250	1.042	70.0	2.083	89.0	231.5	1885	335.1	16.8
24	B		250	1.042	70.0	1.042	140.0	232.2	1955	323.1	16.2
25	A		250	1.042	70.0	1.042	140.0	231.5	2025	311.9	15.6

Client: THEA
 Project: THEA Aesthetic Lighting

Load Center: KK - STA. 373+98.67
 Conductor Type: THWN COPPER
 Circuit Type: 480/240 VAC, 2 PHASE, 3 WIRE + GROUND
 Direction: EB - GROUND
 Maximum Voltage Drop: 5%
 Minimum Fault Current Ratio: 5:1

CKT #	Phase	Load Amps	BRKR Amps
8	A	13.5	20
8	B	12.5	20

PHASE-TO-NEUTRAL VOLTAGE =	240
CONDUCTOR SIZE =	2
GROUND SIZE =	2
CALCULATED % VOLTAGE DROP =	3.6
CALCULATED FAULT CURRENT RATIO =	15.2

Load #	Phase	Load Description	Load (VA)	Load (amps)	Dist.-Previous load (feet)	Segment Load	Segment Dist. (ft)	Actual Voltage	Total Run Dist. (ft)	Fault Current	Fault Cur. Ratio
1	A	RW1 N	250	1.042	1416.0	13.542	1416.0	232.7	1416	446.0	22.3
2	B		250	1.042	19.0	12.500	1435.0	233.2	1435	440.1	22.0
3	A		250	1.042	19.0	12.500	38.0	232.5	1454	434.4	21.7
4	B		250	1.042	19.0	11.458	38.0	233.0	1473	428.8	21.4
5	A		250	1.042	19.0	11.458	38.0	232.4	1492	423.3	21.2
6	B		250	1.042	19.0	10.417	38.0	232.9	1511	418.0	20.9
7	A		250	1.042	19.0	10.417	38.0	232.2	1530	412.8	20.6
8	B		250	1.042	19.0	9.375	38.0	232.7	1549	407.7	20.4
9	A		250	1.042	19.0	9.375	38.0	232.1	1568	402.8	20.1
10	B		250	1.042	19.0	8.333	38.0	232.6	1587	398.0	19.9
11	A		250	1.042	19.0	8.333	38.0	232.0	1606	393.3	19.7
12	B		250	1.042	19.0	7.292	38.0	232.5	1625	388.7	19.4
13	A		250	1.042	19.0	7.292	38.0	231.9	1644	384.2	19.2
14	B		250	1.042	19.0	6.250	38.0	232.4	1663	379.8	19.0
15	A		250	1.042	19.0	6.250	38.0	231.8	1682	375.5	18.8
16	B		250	1.042	19.0	5.208	38.0	232.3	1701	371.3	18.6
17	A		250	1.042	19.0	5.208	38.0	231.7	1720	367.2	18.4
18	B		250	1.042	19.0	4.167	38.0	232.3	1739	363.2	18.2
19	A		250	1.042	19.0	4.167	38.0	231.6	1758	359.3	18.0
20	B		250	1.042	19.0	3.125	38.0	232.2	1777	355.4	17.8
21	A		250	1.042	19.0	3.125	38.0	231.6	1796	351.7	17.6
22	B		250	1.042	70.0	2.083	89.0	232.2	1866	338.5	16.9
23	A		250	1.042	70.0	2.083	140.0	231.5	1936	326.2	16.3
24	B		250	1.042	70.0	1.042	140.0	232.1	2006	314.8	15.7
25	A		250	1.042	70.0	1.042	140.0	231.4	2076	304.2	15.2

APPENDIX E: PHOTOMETRIC ANALYSIS

Bid Alternative
Photometric Analysis

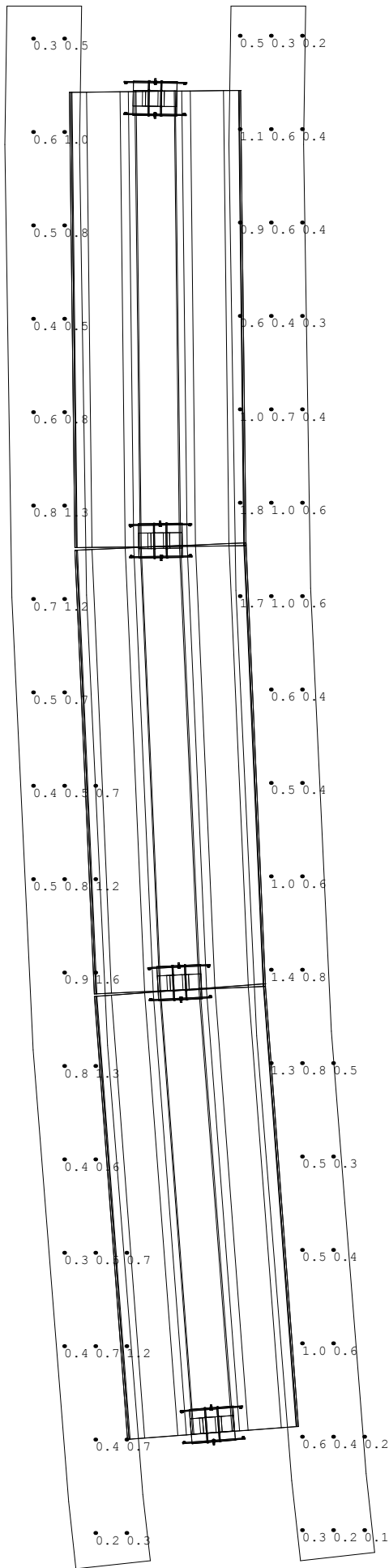

Photometric Analysis - Piers

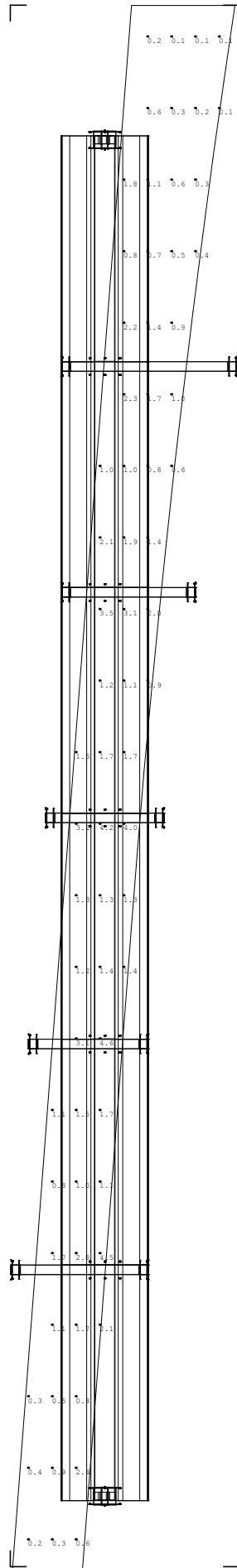

Photometric Analysis - Straddle Bents

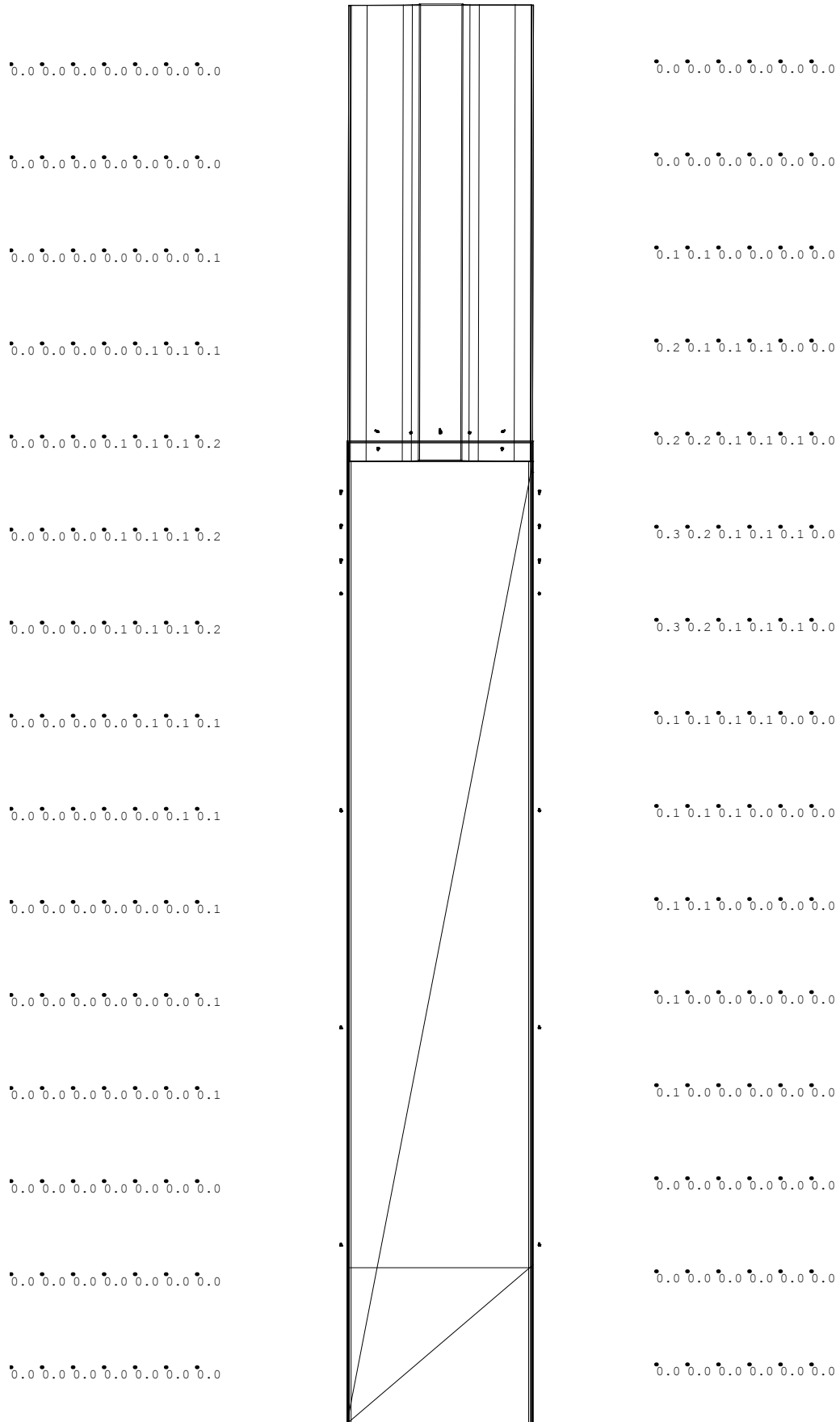

Photometric Analysis – Retaining Walls and Abutments